

INSTRUCTION MANUAL

TECO INVERTER

200V Class

1/3 phase 0.75~2.2KW
1~3HP

3 phase 3.7~75 KW
5~100HP

400V Class

3 phase 0.75~160KW
1~215HP



TECO INVERTER

A510 Series

Contents

Chapter 1 Safety precautions	1
1.1 Before supplying power	1
1.2 Wiring	2
1.3 Before operation	2
1.4 Parameters setting	3
1.5 Operation.....	3
1.6 Maintenance, Inspection and Replacement.....	4
Chapter 2 Model Description	5
2.1 Nameplate Data.....	5
2.2 Model Designation.....	5
Chapter 3 Ambient Environment And Installation	6
3.1 Screw Torques for terminals.....	6
3.2 Wiring the periphery devices of A510	7
3.3 Wiring	8
3.4 Terminal Description.....	9
3.5 Overall Dimension drawing.....	12
3.5.1 Standard Model	12
3.5.2 Built-in filter model (440V 1~60HP)	16
Chapter 4 Software Index	18
4.1 Keypad Description.....	18
4.1.1 Panel Functions.....	18
4.2 Parameters list.....	19
Chapter 5 Trouble Diagnosis and shooting	62
5.1 General.....	62
5.2 Fault detection function	62
5.3 Warning / self-diagnosis detection function	66
5.4 Auto-tuning error.....	72
5.5 PM motor auto-tuning error	73

Chapter 1 Safety Precautions

1.1 Before supplying power



Warning

- The main circuit must be properly wiring. Single phase(R/L1, S/L2)/3-phase(R/L1, S/L2, T/L3) are the input terminal of the power, which must not be mixed with U/T1,V/T2 and W/T3 on use. In case of mixed use, supplying power will damage the inverter.



Caution

- The power voltage must be the same as the input voltage of the inverter.
- When handling the inverter, do not draw the front cover directly. It is suggested to handle the inverter body so as to prevent the front cover breaks off, avoiding the inverter falling and causing injury or inverter damage.
- Please mount the inverter on noncombustible materials such as metal. Mounting on or near the flammable materials is not allowed in case fire happened.
- If several inverters are mounted on a single control panel, the extra cooling fan shall be added, so as to make the panel temperature below 40 °C and to prevent overheating or fire.
- Please firstly turn off the power before disassemble or assemble the operator. Fix the operator according to the indicating diagram to avoid operation failure or no display due to improper operation.



Warning

- This product has passed the application level at IEC 61800-3 restricted areas. When the product is used in some environments, there might be electromagnetic interference. Therefore, appropriate test is recommended to be carried out before use and grounding must be well done.



Caution

- Installation and use of the product must be conducted by a qualified professional electrician.
- The product installation must be applied by the means of fixed wiring.

1.2 Wiring



Warning

- Always turn OFF the input power supply before inverter installation or wiring terminals, so as to avoid electric shock or fire.
- Wiring must be performed by an authorized person qualified in electrical work, to avoid electric shock or fire.
- Make sure the grounding terminal is well grounded. (220 V class: Grounding impedance shall be less than 100Ω, 460 V class: Grounding impedance shall be less than 10Ω)
- Always test the operation of any emergency stop circuits after wiring. (Wiring is the responsibility of the user.)
- Never touch the input/output lines directly with your hands or allow any line to contact the Inverter case. Never short the circuits.
- Do not carry out the dielectric voltage withstand test on the inverter, which will cause the semiconductor parts damage easily.



Caution

- Make sure the input power meets that of the inverter, in order to avoid injury or fire.
- Please connect the braking resistor and braking unit according to the related wiring diagram in case fire occurred.
- Please fasten the terminal screws based on specified torque so as to avoid fire.
- Do not connect the input power supply line to the output terminal of the inverter.
- Do not connect the magnetic contactor and solenoid switch contacts to the output terminal.
- Do not connect the phase advancing capacitor or LC / RC filter to the output circuit.
- Ensure the interference generated by the inverter and motor will not affect peripheral sensors or devices.

1.3 Before operation



Warning

- Make sure the inverter capacity is the same as the capacity set by inverter's function parameters 13—00 before supplying power.
- If the line length between the inverter and the motor exceeds 25 meters, it needs to reduce the carrier frequency (11-01) or additionally equip a output filter to reduce the over-voltage or oscillation at the load end, so as to avoid motor damage.

1.4 Parameters setting



Caution

- When carry out the rotatable automatic tuning, do not connect the motor to the load (mechanical device).
- When carry out the rotatable automatic tuning and the motor will rotate, make sure around space of the motor is enough in order to avoid danger.

1.5 Operation



Warning

- Make sure the front external cover is completely installed in prior to turn on the power.
- Do not connect or disconnect the motor unit in operation, otherwise the inverter will cause the inverter to trip because of over-current. The severe case will cause the main circuit damage of the inverter.
- When the reset function is in operation, keep away from the machine. The machine will restart after the fault is cleared.
- Do not operate the machine with wet hands.
- It provides a independent emergency stop switch. This switch will be enabled when the parameter is being set (see 11-55).
- It provides an independent external hardware emergency switch, which emergently shuts down the inverter output in the case of danger.
- Make sure the operation order is closed before reset warning.
- If choose to automatically restart after power recovery (07-00), the inverter will start automatically after power is restored.
- Before automatic tuning, make sure the conditions of surrounding systems and mechanical devices to ensure the safety of personnel.
- Never touch related terminals regardless of inverter in operation or in stop states to avoid any danger.
- After the power is cut off, the fan might continue to rotate for some time.



Caution

- Do not touch the heating elements such as heat sink, braking resistor, etc. 
- The inverter enables easily the motor rotates from low speed to high speed. Please make sure the allowable range of the motor and the machine.
- When the product is supported by the use of the braking module, please pay attention to related settings for operation.
- Inspecting the circuit board signal should be avoided when the inverter is in operation.



Warning

- Avoid electrical shock! The internal DC capacitor of the inverter discharges in 5 minutes after the power is cut off. Therefore, carry out disassembly/assembly or inspection after 5 minutes when the discharge completes.

1.6 Maintenance, Inspection and Replacement



Warning

- Before the maintenance and inspection, make sure the power is cut off and the indicator light of the power is off (make sure the DC voltage does not exceed 25 v).
- Since there are high voltage terminals in the inverter, do not touch these terminals randomly.
- In the case of power on, be sure the protection cover is installed. In addition, when the protection cover is disassembled, be sure to cut off the power by the circuit breaker.
- Only the designated professional can carry out the maintenance or parts replacement.



Caution

- The ambient temperature of the inverter should be from -10°C to $+40(60)^{\circ}\text{C}$ 95%RH and the inverter shall be used in the non-condensing environment, free from water dropping and metal dust in surrounding.

Disposal caution for the inverter



Caution

Treat as industrial waste when disposing of inverter and pay attention to the following items:

- Burning electrolytic capacitors of the inverter main circuit and printed circuit board might cause explosion;
- Burning the plastic parts such as inverter shell will produce toxic gases.

Chapter 2 Model Description

2.1 Nameplate Data

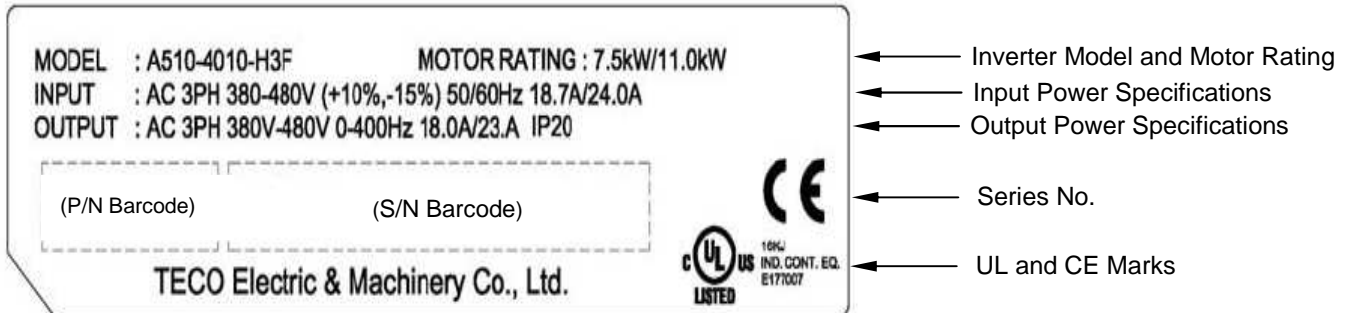

2.2 Model Designation

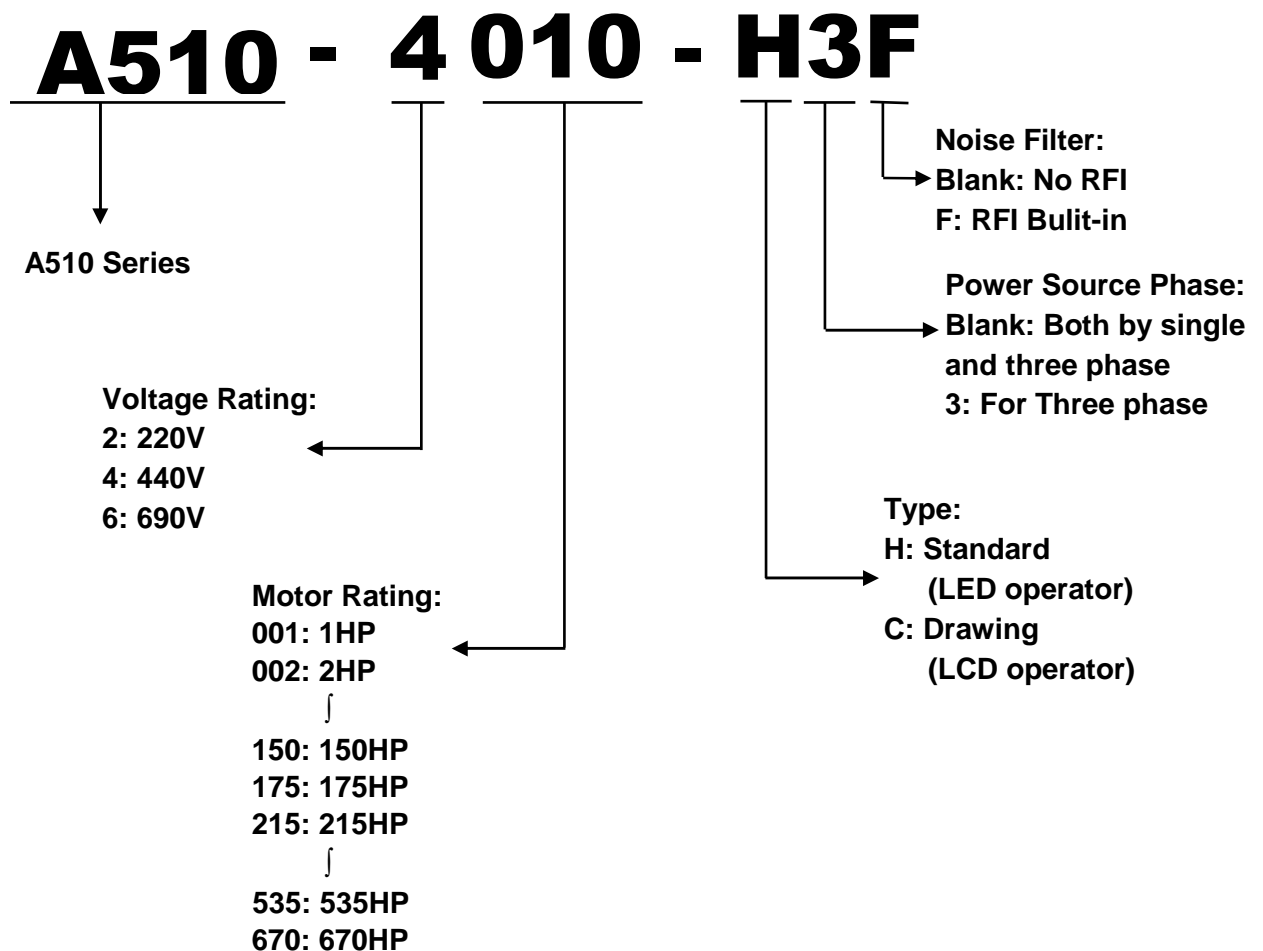

Chapter 3 Ambient Environment And Installation

3.1 Screw Torques for terminals

To comply with UL standards, you shall use UL approved copper wires (rated 75 °C) and round crimp terminals (UL Listed products) in the following table when connecting the main circuit terminal. TECO recommends using crimp terminals manufactured by NICHIFU Terminal Industry Co., Ltd and the terminal crimping tool recommended by the manufacturer for crimping terminals and the insulating sleeve.

Wire size mm ² (AWG)	Terminal screw size	Model of the round crimp terminal	Fastening torque kgf.cm (in.lbs)	Model of insulating sleeve	Model of crimp tool
0.75 (18)	M3.5	R1.25-3.5	8.2 to 10 (7.1 to 8.7)	TIC 1.25	NH 1
	M4	R1.25-4	12.2 to 14 (10.4 to 12.1)	TIC 1.25	NH 1
1.25 (16)	M3.5	R1.25-3.5	8.2 to 10 (7.1 to 8.7)	TIC 1.25	NH 1
	M4	R1.25-4	12.2 to 14 (10.4 to 12.1)	TIC 1.25	NH 1
2 (14)	M3.5	R2-3.5	8.2 to 10 (7.1 to 8.7)	TIC 2	NH 1 / 9
	M4	R2-4	12.2 to 14 (10.4 to 12.1)	TIC 2	NH 1 / 9
	M5	R2-5	22.1 to 24 (17.7 to 20.8)	TIC 2	NH 1 / 9
	M6	R2-6	25.5 to 30.0 (22.1 to 26.0)	TIC 2	NH 1 / 9
3.5/5.5 (12/10)	M4	R5.5-4	12.2 to 14 (10.4 to 12.1)	TIC 5.5	NH 1 / 9
	M5	R5.5-5	20.4 to 24 (17.7 to 20.8)	TIC 5.5	NH 1 / 9
	M6	R5.5-6	25.5 to 30.0 (22.1 to 26.0)	TIC 5.5	NH 1 / 9
	M8	R5.5-8	61.2 to 66.0 (53.0 to 57.2)	TIC 5.5	NH 1 / 9
8 (8)	M4	R8-4	12.2 to 14 (10.4 to 12.1)	TIC 8	NOP 60
	M5	R8-5	20.4 to 24 (17.7 to 20.8)	TIC 8	NOP 60
	M6	R8-6	25.5 to 30.0 (22.1 to 26.0)	TIC 8	NOP 60
	M8	R8-8	61.2 to 66.0 (53.0 to 57.2)	TIC 8	NOP 60
14 (6)	M4	R14-4	12.2 to 14 (10.4 to 12.1)	TIC 14	NH 1 / 9
	M5	R14-5	20.4 to 24 (17.7 to 20.8)	TIC 14	NH 1 / 9
	M6	R14-6	25.5 to 30.0 (22.1 to 26.0)	TIC 14	NH 1 / 9
	M8	R14-8	61.2 to 66.0 (53.0 to 57.2)	TIC 14	NH 1 / 9
22 (4)	M6	R22-6	25.5 to 30.0 (22.1 to 26.0)	TIC 22	NOP 60/ 150H
	M8	R22-8	61.2 to 66.0 (53.0 to 57.2)	TIC 22	NOP 60/ 150H
30/38 (3 / 2)	M6	R38-6	25.5 to 30.0 (22.1 to 26.0)	TIC 38	NOP 60/ 150H
	M8	R38-8	61.2 to 66.0 (53.0 to 57.2)	TIC 38	NOP 60/ 150H
50 / 60 (1 / 1 / 0)	M8	R60-8	61.2 to 66.0 (53.0 to 57.2)	TIC 60	NOP 60/ 150H
	M10	R60-10	102 to 120 (88.5 to 104)	TIC 60	NOP 150H
70 (2/0)	M8	R70-8	61.2 to 66.0 (53.0 to 57.2)	TIC 60	NOP 150H
	M10	R70-10	102 to 120 (88.5 to 104)	TIC 60	NOP 150H
80 (3/0)	M10	R80-10	102 to 120 (88.5 to 104)	TIC 80	NOP 150H
	M16	R80-16	255 to 280 (221 to 243)	TIC 80	NOP 150H
100 (4/0)	M10	R100-10	102 to 120 (88.5 to 104)	TIC 100	NOP 150H
	M12	R100-12	143 to 157 (124 to 136)	TIC 100	NOP 150H
	M16	R80-16	255 to 280 (221 to 243)	TIC 80	NOP 150H

3.2 Wiring the periphery devices of A510

Power supply



No Fuse Breaker (NFB) and Leakage Circuit Breaker



Electromagnetic contactor



AC reactor

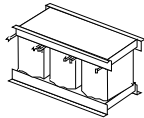

Fast acting fuse



Input Noise filter



Inverter



Zero-phase noise filter



3-phase induction motor

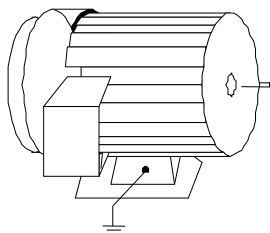

■ No fuse breaker (NFB) and Leakage Circuit Breaker

- Please refer to table 3 for choosing NFB of appropriate current.
- Do not use NFB to control the start/stop of the inverter.
- If a leakage circuit breaker is added for leakage protection, its current sensitivity shall be more than 200mA and action time more than 0.1 (V-TYPE), so as to avoid high-frequency malfunction.

■ Electromagnetic contactor

- It can not add the electromagnetic contactor for general use. However, for the application requiring external sequence control or automatic restart function after power cut, an electromagnetic contactor is required.
- Please avoid using electromagnetic contactor for the start/stop control of the inverter as possible.

■ AC reactor

- In case of further improving the power factor or suppress the external surge, an AC reactor can be additionally equipped.

■ Fast acting fuse

- To protect interface devices, it is necessary to add a fast acting fuse (fuse specification will be referred to Section 6.6 in completed manual.)

■ Input Noise filter

- A510 is matched with TECO special filter, meeting the EN 55011 class A criterion.
- The selection of input noise filter can be referred to Section 6.4 in completed manual.)

■ Inverter

- Terminal R,S,T at input side have no phase sequence requirement, thus they can be arbitrarily exchanged.
- Terminal E must be well grounded.

■ Zero-phase noise filter

- Adding a zero-phase noise filter at the output side of the inverter can decrease the radiated interference and induced noise.
- Please refer to Section 6.5 in completed manual.

■ Motor

- If an inverter drives multiple motors, the rated current of the inverter must be greater than the total current that all motors operate at the same time.
- Motor and inverter must be grounded respectively.

3.3 Wiring

The following is the standard wiring diagram for the A510 inverter (⊙ indicates main circuit terminal, ○ indicates control circuit terminal). Locations and symbols of the wiring terminal block might be different due to different models of A510. The description of main circuit terminal and control circuit terminal can be referred to table 1 and 2.

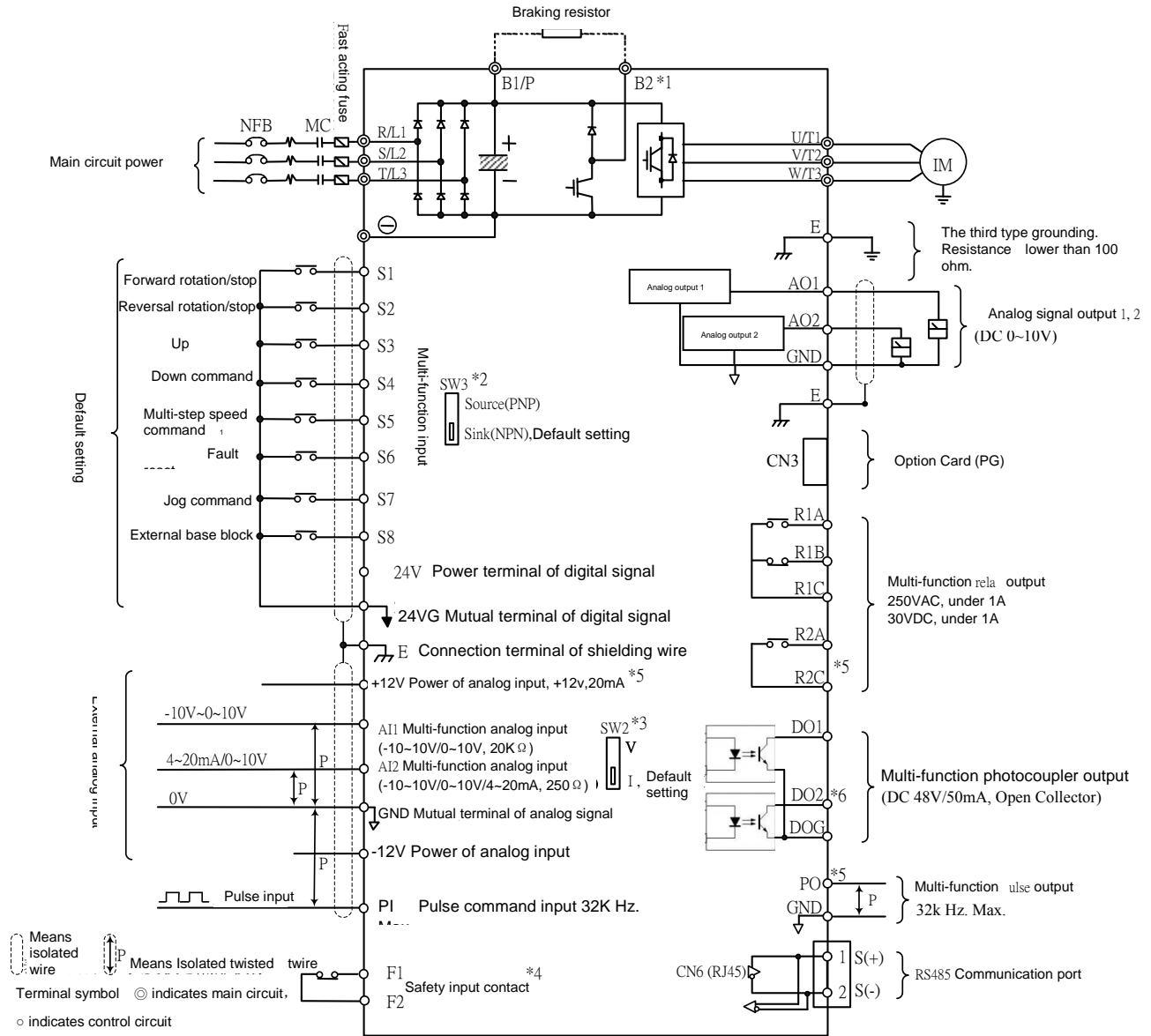

Remark:

- *1: Only the master circuit of 220V1~25HP and 440 V1~30HP (included) or models of lower capacity with built-in braking resistor provide terminal B2. The braking resistor can be connected directly between B1 and B2.
- *2: The multi-function digital input terminals S1~S8 can be set to Source (PNP) or Sink (NPN) mode through the SW3.
- *3: Multi-function analog input 2 (AI2) can be set to the voltage command input (0-10/-10-10v) or the current command input (4~20mA) through the SW3.
- *4: Safety input connector F1 and F2 should be shorted so that the inverter outputs properly. When the safety input is used, please be sure to remove the short-pin between F1 and F2.
- *5: Only 220 V 3HP and 440 v 5HP (included) or models above, provide terminals -12V, R2A-R2C and PO-GND.
- *6: Only 220 V 2HP and 440 v 3HP (included) or models below, provide terminal DO2.

3.4 Terminal Description

Table 1 Major Circuit Terminals

Terminal mark	220V: 1~25HP 440V: 1~30HP	220V: 30~100HP 440V: 40~215HP
R/L1	Power supply of the main terminal (single phase, only connect R-S)	
S/L2		
T/L3		
B1 / P	• B1 / P— \ominus : DC power supply	-
B2		
\ominus	• B1 / P—B2: externally connected braking resistor	• \oplus - \ominus : DC power supply or connect braking detection module
\oplus		
U/T1	Inverter output	
V/T2		
W/T3		
E	Grounding terminal (the third type grounding)	

Table 2 Main circuit terminals

Type	Terminal	terminal function	Signal level
Digital input signal	S1	Forward rotation— stop command (default), multi-function input terminals * 1	24 VDC, 8 mA opto-coupler isolation (maximum voltage of 30 Vdc, input impedance of 9.03k Ω optocoupler)
	S2	Reversal rotation- stop command (default), multi-function input terminals * 1	
	S3	UP increases command(default), multi-function input terminals * 1	
	S4	DOWN reduces command(default), multi-function input terminals * 1	
	S5	Multi-step speed frequency command 1, multi-function input terminal* 1	
	S6	fault reset input, multi-function input terminal * 1	
	S7	JOG frequency command, multi-function input terminal * 1	
	S8	External B.B.(Base Block) input, multi-function input terminal * 1	
24V Power supply	24V	Digital signal SOURCE sharing point (SW3 switched to SOURCE)	$\pm 15\%$, Maximum output current: 250mA(the sum of all load)
	24VG	Common terminal of Digital signals Common point of digital signal SINK (SW3 switched to SINK)	

Type	Terminal	terminal function	Signal level
Analog input signal	+12V	Power for speed setting	+12V (Maximum current , 20mA)
	-12V	Only above 220V 3HP/ 440V 5HP (include) support this terminal function	-12V (Maximum current, 20mA)
	AI1	Voltage mastering speed command (0-10V input)/(-10V~10V input)	From 0 to +10V, From -10V to +10V (Input impedance : 20KΩ) (11bit + 1 symbol, resolution)
	AI2	Multi-function analog input terminals *2, can use SW2 to switch voltage or current input (0~10V)/(4-20mA)	From 0 to +10V, From -10V to +10V (Input impedance: 20KΩ) From 4 to 20 mA (Input impedance: 250KΩ) (11bit + 1 symbol, resolution)
	GND	Analog signals sharing terminal	----
	E	Shielding wire's connecting terminal (Ground)	----
Analog output signal	AO1	Multi-function analog output terminals *3 (0~10V output)	From 0 to 10V, (Maximum current, 20mA) (PWM 10KHz resolution)
	AO2	Multi-function analog output terminals *3 (0~10V output)	
	GND	Analog signals sharing terminal	
Pulse output signal	PO	Pulse output, BW 32KHz, only above 220V 3HP/ 440V 5HP (include) support this terminal function.	32KHz(max), +12V output (load: 2.2kΩ)
	GND	Analog signals sharing terminal	----
Pulse input signal	PI	Pulse command input, frequency width of 32KHz	L: from 0.0 to 0.5V H: from 4.0 to 13.2V 0 - 32 KHz(max) (impedance:3.89 KΩ)
	GND	Analog signals sharing terminal	----
Digital output	DO1	Multi-function(open collector resistor) output: in operation, zero speed, frequency consistency, consistency at any frequency, output frequency , preparation completion, low-voltage detection, output breaker, rotation and frequency command, over-torque detection, abnormal, low-voltage, Overheat, motor overload, inverter overload, retrying, communication error, timing functional output device.....	48Vdc, 2~50mA Opto-coupling output
	DO2 (F1 only)		
	DOG	Sharing terminal of the open collector transistor	

Type	Terminal	terminal function	Signal level
Relay output	R1A	Relay A contact (multi-function output terminal)	Terminal capacity: at 250Vac, 10 mA~1A at 30Vdc, 10 mA~1A
	R1B		
	R1C	Relay B contact (multi-function output terminal) Relay common terminal, With the same function as DO1/DO2	
	R2A-R2C (above F2)	With the same function as DO1/DO2	
safety input	F1	on: free rotation with safe input off: general rotation (if use external safety switch to stop, you must remove the short circuit pin.)	24Vdc, 8mA, pull-high
	F2	Safety command common terminal	24V Ground
RS-485 port	S (+)	RS485/MODBUS	Opto-coupler isolation, differential input and output
	S (-)		
Grounding	E (G)	Grounding to earth Shield the connecting terminal	----

*1:Multi-function digital input can be referred to the manual.

*2:Multi-function analog input can be referred to the manual.

*3:Multi-function analog output can be referred to the manual.



Caution

- Maximum output current capacity of the terminal 12V is 20mA.
- Multi-function analog output AO1 and AO2 are special for the analog output of meter. Please don't use them to the analog signal output of feedback control.
- Control board's 24V & 12V just been used for internal control, please don't connect to external other devices to use.

3.5 Overall Dimension drawing

3.5.1 Standard Model

(a) 220V :1-5HP/440V :1-7.5HP

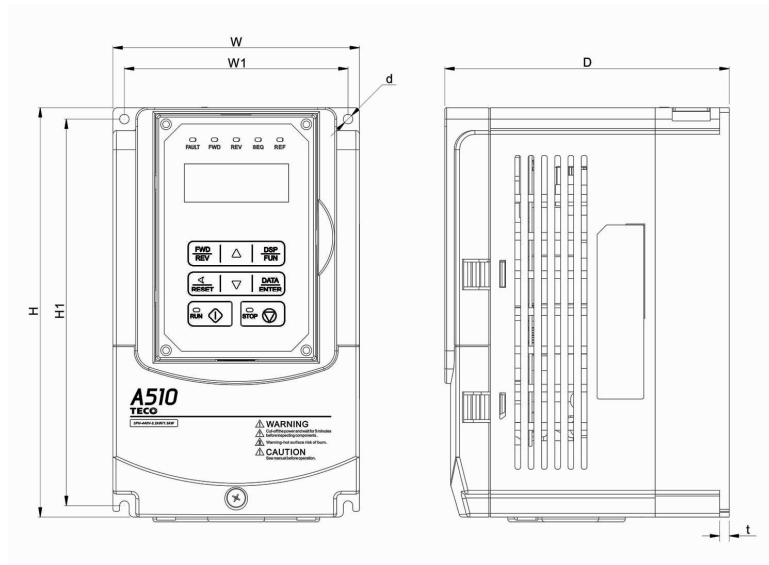

Inverter Model	Dimension (mm)								Reactor
	W	H	D	W1	H1	t	d	GW(kg)	
A510-2001-H	130	215	150	118	203	5	M5	2.2	with option DCL
A510-2002-H	130	215	150	118	203	5	M5	2.2	
A510-2003-H	140	279	177	122	267	7	M5	3.8	
A510-2005-H3	140	279	177	122	267	7	M5	3.8	
A510-4001-H3	130	215	150	118	203	5	M5	2.2	
A510-4002-H3	130	215	150	118	203	5	M5	2.2	
A510-4003-H3	130	215	150	118	203	5	M5	2.2	
A510-4005-H3	140	279	177	122	267	7	M5	3.8	
A510-4008-H3	140	279	177	122	267	7	M5	3.8	

(b) 220V :7.5-25HP/440V :10-30HP

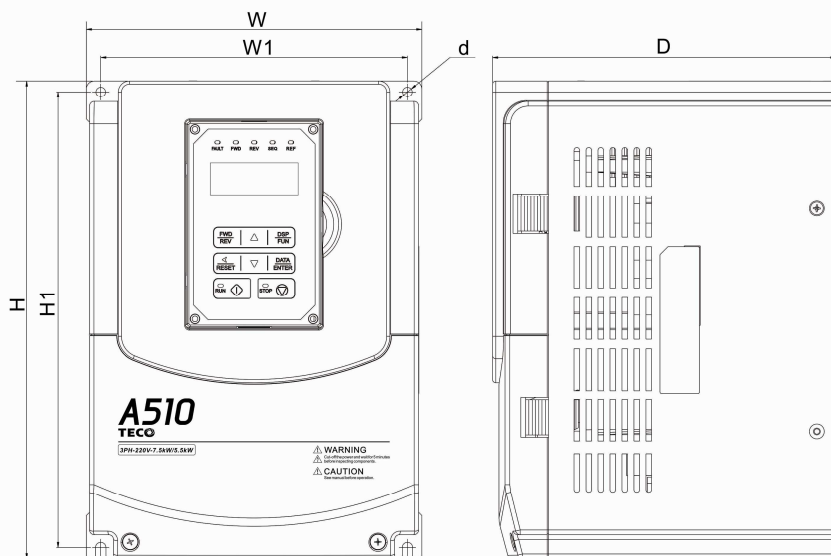

Inverter Model	Dimension (mm)								Reactor
	W	H	D	W1	H1	t	d	GW(kg)	
A510-2008-H3	210	300	215	192	286	1.6	M6	6.2	with option ACL
A510-2010-H3	210	300	215	192	286	1.6	M6	6.2	
A510-2015-H3	265	360	225	245	340	1.6	M6	10	
A510-2020-H3	265	360	225	245	340	1.6	M6	10	
A510-2025-H3	265	360	225	245	340	1.6	M6	10	
A510-4010-H3	210	300	215	192	286	1.6	M6	6.2	
A510-4015-H3	210	300	215	192	286	1.6	M6	6.2	
A510-4020-H3	265	360	225	245	340	1.6	M6	10	
A510-4025-H3	265	360	225	245	340	1.6	M6	10	
A510-4030-H3	265	360	225	245	340	1.6	M6	10	

(c) 220V :30-40HP/440V :40-60HP

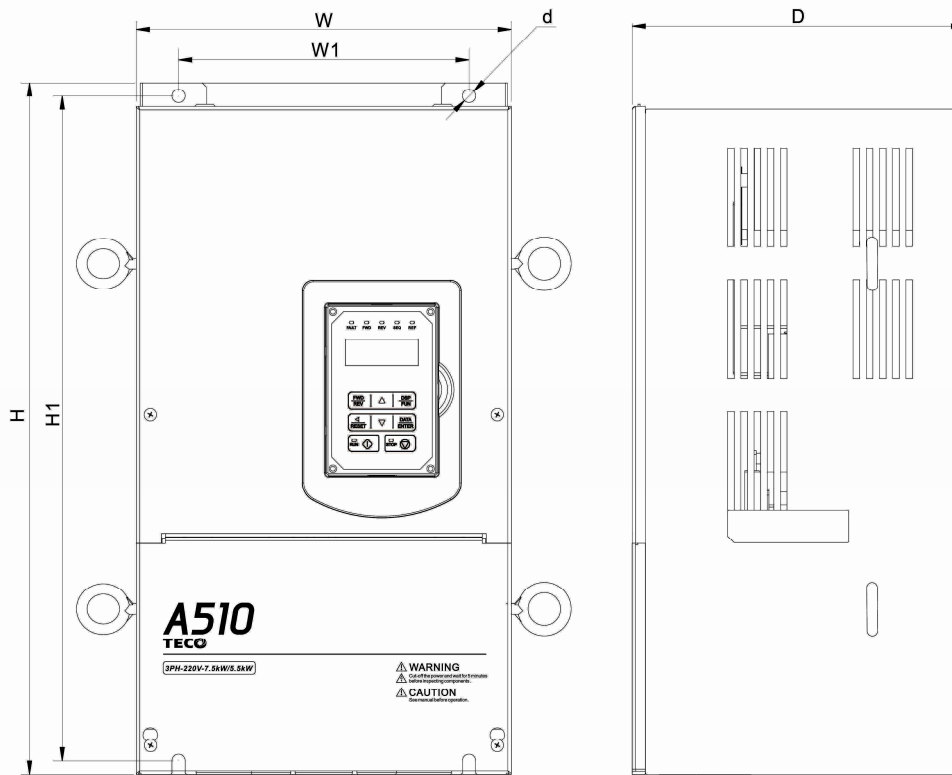

Inverter Model	Dimension (mm)								Reactor
	W	H	D	W1	H1	t	d	GW(kg)	
A510-2030-H3	284	525	252	220	505	1.6	M8	30	with option ACL
A510-2040-H3	284	525	252	220	505	1.6	M8	30	
A510-4040-H3	284	525	252	220	505	1.6	M8	30	
A510-4050-H3	284	525	252	220	505	1.6	M8	30	
A510-4060-H3	284	525	252	220	505	1.6	M8	30	

(d) 220V :50-100HP/440V :75-215HP(IP00)

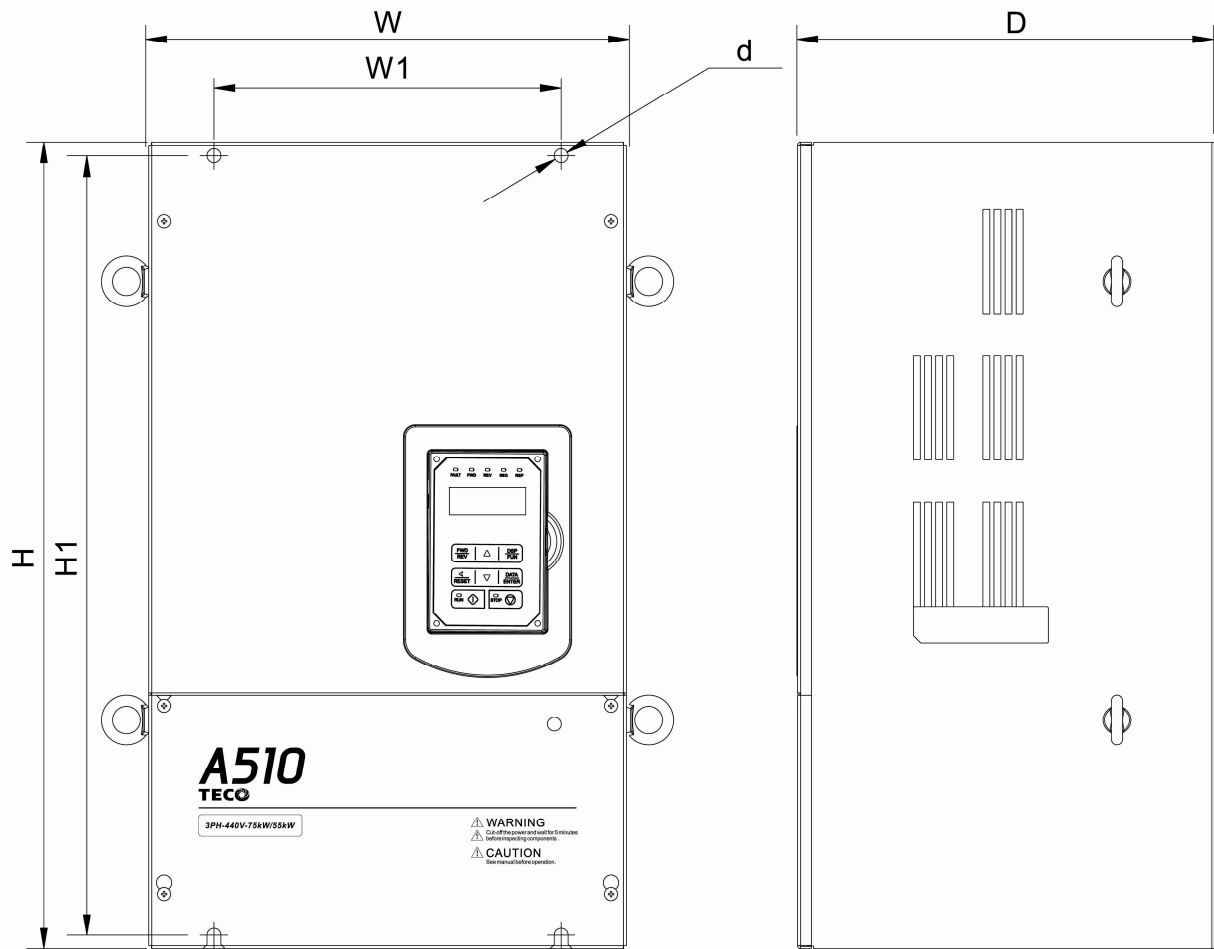

Inverter Model	Dimension (mm)								Reactor
	W	H	D	W1	H1	t	d	GW(kg)	
A510-2050-H3	344	580	300	250	560	1.6	M8	40.5	DCL STANDARD INCLUDED
A510-2060-H3	344	580	300	250	560	1.6	M8	40.5	
A510-2075-H3	459	790	324.5	320	760	1.6	M10	74	
A510-2100-H3	459	790	324.5	320	760	1.6	M10	74	
A510-4075-H3	344	580	300	250	560	1.6	M8	40.5	
A510-4100-H3	344	580	300	250	560	1.6	M8	40.5	
A510-4125-H3	459	790	324.5	320	760	1.6	M10	74	
A510-4150-H3	459	790	324.5	320	760	1.6	M10	74	
A510-4175-H3	459	790	324.5	320	760	1.6	M10	74	
A510-4215-H3	459	790	324.5	320	760	1.6	M10	74	

(e) 220V :50-100HP/440V :75-215HP(IP20)

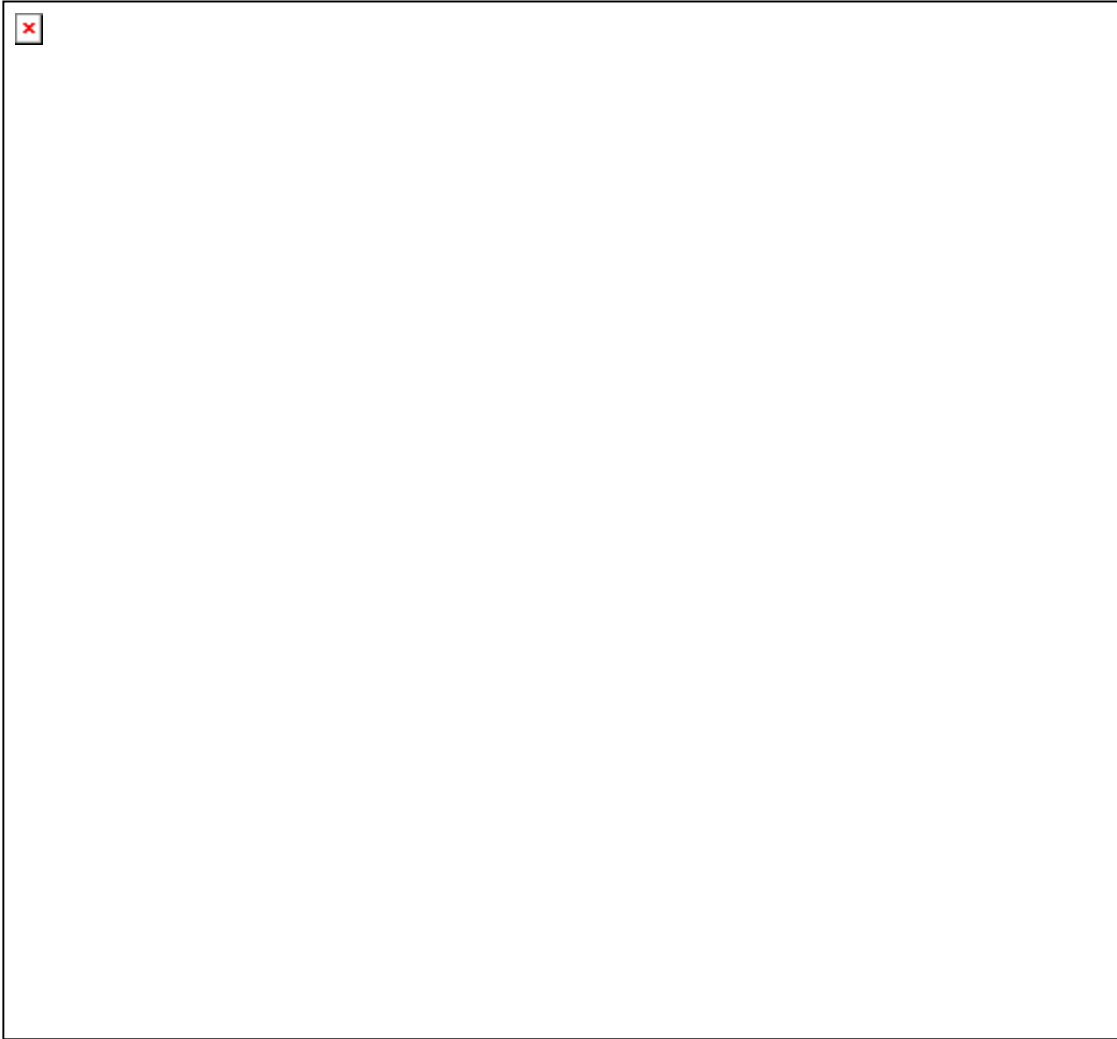

Inverter Model	Dimension (mm)								Reactor
	W	H	D	W1	H1	t	d	GW(kg)	
A510-2050-H3	348.5	740	300	250	560	1.6	M8	44	DCL STANDARD INCLUDED
A510-2060-H3	348.5	740	300	250	560	1.6	M8	44	
A510-2075-H3	463.5	1105	324.5	320	760	1.6	M10	81	
A510-2100-H3	463.5	1105	324.5	320	760	1.6	M10	81	
A510-4075-H3	348.5	740	300	250	560	1.6	M8	44	
A510-4100-H3	348.5	740	300	250	560	1.6	M8	44	
A510-4125-H3	463.5	1105	324.5	320	760	1.6	M10	81	
A510-4150-H3	463.5	1105	324.5	320	760	1.6	M10	81	
A510-4175-H3	463.5	1105	324.5	320	760	1.6	M10	81	
A510-4215-H3	463.5	1105	324.5	320	760	1.6	M10	81	

Note: 250HP or above are being developed

3.5.2 Built-in filter model (440V 1~60HP)

(a) 440V :1-7.5HP

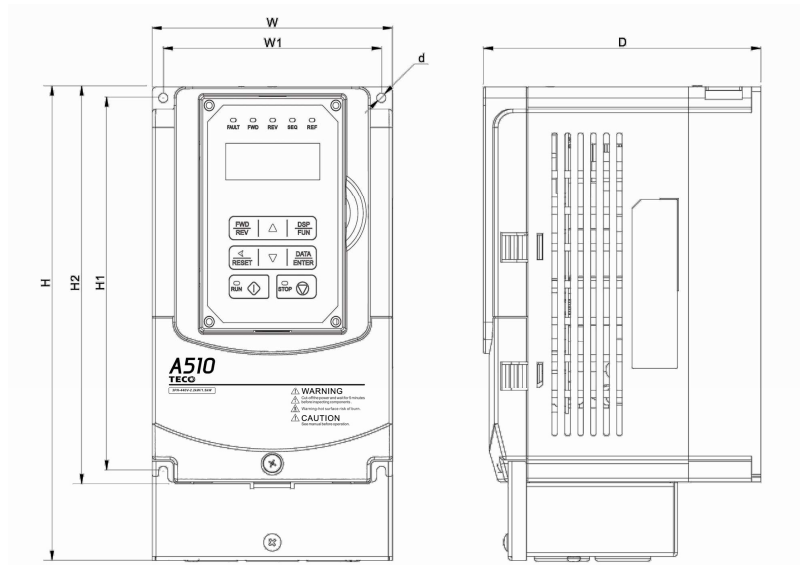

Inverter Model	Dimension (mm)									Reactor
	W	H	D	W1	H1	H2	t	d	GW(kg)	
A510-4001-H3F	130	265	150	118	203	215	5	M5	2.83	with option ACL
A510-4002-H3F	130	265	150	118	203	215	5	M5	2.83	
A510-4003-H3F	130	265	150	118	203	215	5	M5	2.83	
A510-4005-H3F	140	349	177	124	266	279	7	M5	4.72	
A510-4008-H3F	140	349	177	124	266	279	7	M5	4.72	

(b) 440V :10-30HP

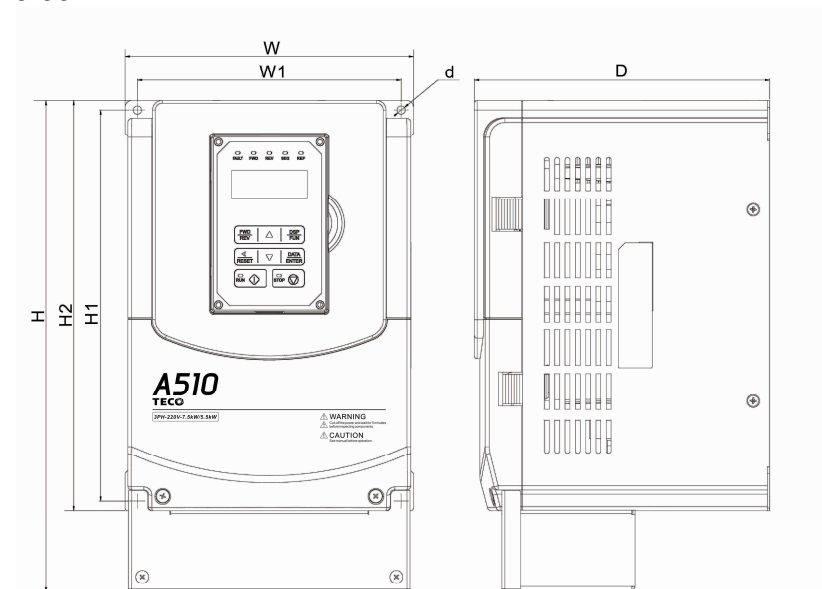

Inverter Model	Dimension (mm)									Reactor
	W	H	D	W1	H1	H2	t	d	GW(kg)	
A510-4010-H3F	210	385	215	192	286	300	1.6	M6	7.72	with option DCL
A510-4015-H3F	210	385	215	192	286	300	1.6	M6	7.72	
A510-4020-H3F	265	480	225	245	340	360	1.6	M6	11.6	
A510-4025-H3F	265	480	225	245	340	360	1.6	M6	11.6	
A510-4030-H3F	265	480	225	245	340	360	1.6	M6	11.6	

(c) 440V :40-60HP

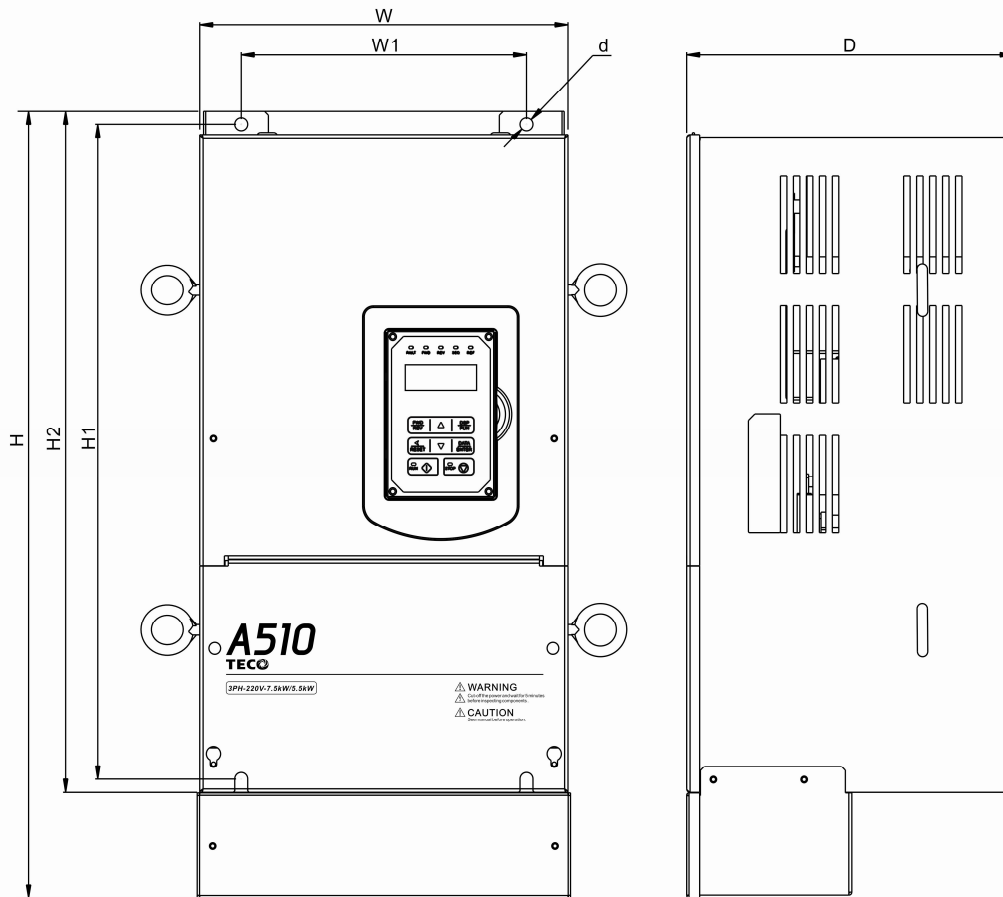

Inverter Model	Dimension (mm)									Reactor
	W	H	D	W1	H1	H2	t	d	GW(kg)	
A510-4040-H3F	284	695	252	220	505	525	1.6	M8	32.24	with option ACL
A510-4050-H3F	284	695	252	220	505	525	1.6	M8	32.24	
A510-4060-H3F	284	695	252	220	505	525	1.6	M8	32.24	

Chapter 4 Software Index

4.1 Keypad Description

4.1.1 Panel Functions



Type	Name	Functions
Display	Main display area	Display frequency, parameter voltage, current, temperature and abnormality and ect.
	LED status display	<p>FAULT: When the inverter has a warning or fault message, the indicator lights up.</p> <p>FWD: When the inverter is in forward rotation status, the indicator lights up. (long bright light while inverter running, flicker while inverter stopping)</p> <p>REV: When the inverter is in reversal rotation status, the indicator lights up. (long bright light while inverter running, flicker while inverter stopping)</p> <p>SEQ: When inverter's run command source is set to external control, the indicator lights up.</p> <p>REF: When inverter's frequency command source is set to external control, the indicator lights up.</p>
Keys (8 keys)	RUN	RUN: Enable the inverter run operation.
	STOP	STOP: Enable the inverter stop operation.
	▲	It is used for frequency and parameter setting.
	▼	It is used for frequency and parameter setting.
	FWD/REV	This key is used for switching motor's rotation direction. FWD indicator on means the motor is rotating in forward direction; REV indicator on means the motor is rotating in reversal direction.
	DSP/FUN	It is use for switching dispay interface, based on the loop of frequency screen →function selection→monitor parameter→frequency screen.

	</RESET	“<” is left shift key. It is used for changing parameter or value. RESET key: when a fault is detected, it plays reset function .
	READ/ENTER	Switch to enter the functions and set internal value, as well as modify parameter setting and confirm the writing.

4.2 Parameters list

Parameter group	Name
Group00	Basic Function Group
Group01	V/F Control Function Group
Group02	IM Motor Parameter Group
Group03	External Terminals Digital Input/Output Function Group
Group04	External terminal analog signal input (output) function group
Group05	Multi-Speed Group
Group06	Automatic Programm Operation Function Group
Group07	Operation /Stop Function Group
Group08	Protection Function Group
Group09	Communication Function Group
Group10	PID Function Group
Group11	Auxiliary Function Group
Group12	Monitoring Function Group
Group13	Maintenance Function Group
Group14	PLC Setting Group
Group15	PLC Monitoring Group
Group16	LCM Function Group
Group17	Automatic Tuning Function Group
Group18	Slip Compensation Group
Group19	Frequency Wobble Function Group
Group20	Speed Control Function Group
Group21	Torque And Position Control Function Group
Group22	IPM Motor Parameter Group

Parameter Attribute	
*1	Modifiable paramters in operation
*2	Unmodifiable parameters in communication
*3	When carry out the factory default setting, this parameter value(set by users) will not restore the factory default.
*4	Readable and unmodifiable parameter

Group 00 Basic Function Group											
Code	Parameter Name	Range	Default	Unit	Control mode						Attribute
					V/F	V/F+PG	SLV	SV	PM SV	PM SLV	
00-00	Control mode Selection	0: V/F	0	-	0	0	0	0	0	0	*3
		1: V/F+PG									
		2: SLV									
		3: SV									
		4: PMSV									
5:retain											
00-01	Motor's rotation direction	0:forward direction	0	-	0	0	0	0	0	0	*1
		1:reversal direction									
00-02	RUN Command Selection	0:keypad control	1	-	0	0	0	0	0	0	
		1: external control									
		2: Communication control									
		3:PLC									
00-03	Retain										
00-04	Retain										
00-05	Main Frequency Command Source Selection	0: keypad	1	-	0	0	0	0	0	0	
		1: external control (Analog)									
		2:Terminal UP/DOWN									
		3: Communication control									
		4:pulse input									
5:PID											
00-06	Retain										
00-07	Retain										
00-08	Communication frequency command	0.00-400.00 0.0~1200.0 (when 00-31 = 1)	0.00	Hz	0	0	0	0	0	0	
00-09	Frequency command memory mode	0:Don't save when power supply is cut.	0	-	0	0	0	0	0	0	
		1: Save when power is off.									
00-10	Retain										
00-11	Retain										
00-12	Upper frequency limit	0.1~109.0	100.0	%	0	0	0	0	0	0	
00-13	Lower frequency limit	0.0~109.0	0.0	%	0	0	0	0	0	0	
00-14	Acceleration time 1	0.1~6000.0	10.0	s	0	0	0	0	0	0	*1
00-15	Deceleration time 1	0.1~6000.0	10.0	s	0	0	0	0	0	0	*1
00-16	Acceleration time 2	0.1~6000.0	10.0	s	0	0	0	0	0	0	*1
00-17	Deceleration time 2	0.1~6000.0	10.0	s	0	0	0	0	0	0	*1
00-18	Jog frequency	0.00~400.00	6.00	Hz	0	0	0	0	0	0	*1
		0.0~1200.0 (when 00-31 = 1)									
00-19	Jog acceleration time	0.1~0600.0	10.0	s	0	0	0	0	0	0	*1
00-20	Jog deceleration time	0.1~0600.0	10.0	s	0	0	0	0	0	0	*1
00-21	Acceleration time 3	0.1~6000.0	10.0	s	0	0	0	0	0	0	*1
00-22	Deceleration time 3	0.1~6000.0	10.0	s	0	0	0	0	0	0	*1
00-23	Acceleration time 4	0.1~6000.0	10.0	s	0	0	0	0	0	0	*1
00-24	Deceleration time 4	0.1~6000.0	10.0	S	0	0	0	0	0	0	*1
00-25	Switching frequency of acceleration and deceleration	0.0~400.0	0.0	Hz	0	0	0	0	0	0	
		0.0~1200.0 (when 00-31 = 1)									

Code	Parameter Name	Range	Default	Unit	Control mode						Attribute
					V/F	V/F+PG	SLV	SV	PM SV	PM SLV	
00-26	Emergency stop time	0.1~6000.0	5.0	s	O	O	O	O	O	O	
00-27	HD/ND selection	0: HD (heavy load mode)	0	-	O	O	X	X	X	X	*3
		1: ND (general load mode)									
00-28	Command characteristic selection of master frequency	0: positive characteristic (0~10V/4~20mA is corresponding to 0~100%)	0	-	O	O	O	O	O	O	
		1: negative characteristic (0~10V/4~20mA is corresponding to 100~0%)									
00-29	Zero-speed operation selection	0: Operation based on frequency command	0	-	X	X	X	O	O	X	
		1: Stop									
		2: Operation based on the lowest frequency									
		3: Zero-speed operation									
00-30	Retain										
00-31	Maximum frequency	0: 400.00Hz	0	-	O	O	X	X	X	X	*3
		1: 1200.0Hz									
00-32	Application adjustment	0: Disable	0	-	O	O	O	O	O	O	
		1: Water supply pump									
		2: Conveyor									
		3: Exhaust fan									
		4: HVAC									
		5: Compressor									
		6: Hoist									
7: Crane											

Group 01 V/F Control Function Group

Code	Parameter Name	Range	Default	Unit	Control mode						Attribute
					V/F	V/F+PG	SLV	SV	PM SV	PM SLV	
01-00	V/F curve selection	0~FF	F	-	O	O	X	X	X	X	*3
01-01	Retain										
01-02	Maximum output frequency of motor 1	40.0~400.0	60.0	Hz	O	O	O	O	O	O	
		40.0~1200.0 (when 00-31 = 1)									
01-03	Maximum output voltage of motor 1	200V: 0.1~255.0	220.0	V	O	O	X	X	X	X	
		400V: 0.2~510.0									
01-04	Middle Output frequency 2 of motor 1	0.0~400.0	0.0	Hz	O	O	X	X	X	X	
		0.0~1200.0 (when 00-31 = 1)									
01-05	Middle Output voltage 2 of motor 1	200V: 0.0~255.0	0.0	V	O	O	X	X	X	X	
		400V: 0.0~510.0									
01-06	Middle Output frequency 1 of motor 1	0.0~400.0	3.0	Hz	O	O	X	X	X	X	
		0.0~1200.0 (when 00-31 = 1)									
01-07	Middle Output voltage 1 of motor 1	200V: 0.0~255.0	14.0	V	O	O	X	X	X	X	
		400V: 0.0~510.0									

Code	Parameter Name	Range	Default	Unit	Control mode						Attribute
					V/F	V/F+PG	SLV	SV	PM SV	PM SLV	
01-08	Minimum output frequency of motor 1	0.0~400.0 0.0~1200.0 (when 00-31 = 1)	1.5	Hz	O	O	O	O	O	O	
01-09	Minimum output voltage of motor 1	200V: 0.0~255.0	7.5	V	O	O	X	X	X	X	
		400V: 0.0~510.0	15.0								
01-10	Torque compensation gain	0.0~2.0	1.0	-	O	O	X	X	X	X	*1
01-11	Retain										
01-12	Base frequency of motor 1	10.0~400.0 10.0~1200.0 (when 00-31 = 1)	60.0	Hz	O	O	O	O	O	O	
01-13	Base output voltage of motor 1	200V: 0.0~255.0	220.0	V	O	O	X	X	X	X	
		400V: 0.0~510.0	440.0								
01-14	Input voltage setting	200V: 155.0~255.0	220.0	V	O	O	O	O	O	O	
		400V: 310.0~510.0	440.0								
01-15	Torque compensation time	1~10000	200	ms	O	O	X	X	X	X	
01-16	Maximum output frequency of motor 2	40.0~400.0 40.0~1200.0 (when 00-31 = 1)	60.0	Hz	O	O	O	O	O	O	
01-17	Maximum output voltage of motor 2	200V: 0.1~255.0	220.0	V	O	O	X	X	X	X	
		400V: 0.2~510.0	440.0								
01-18	Middle Output frequency 2 of motor 2	0.0~400.0 0.0~1200.0 (when 00-31 = 1)	0.0	Hz	O	O	X	X	X	X	
01-19	Middle Output voltage 2 of motor 2	200V: 0.0~255.0	0.0	V	O	O	X	X	X	X	
		400V: 0.0~510.0									
01-20	Middle output frequency 1 of motor 2	0.0~400.0 0.0~1200.0 (when 00-31 = 1)	3.0	Hz	O	O	X	X	X	X	
01-21	Middle output voltage 1 of motor 2	200V: 0.0~255.0	14.0	V	O	O	X	X	X	X	
		400V: 0.0~510.0	28.0								
01-22	Minimum output frequency of motor 2	0.0~400.0 0.0~1200.0 (when 00-31 = 1)	1.5	Hz	O	O	O	O	O	O	
01-23	Minimum output voltage of motor 2	200V: 0.0~255.0	7.5	V	O	O	X	X	X	X	
		400V: 0.0~510.0	15.0								
01-24	Base frequency of motor 2	10.0~400.0 10.0~1200.0 (when 00-31 = 1)	60.0	Hz	O	O	O	O	O	O	
01-25	Base output voltage of motor 2	200V: 0.0~255.0	220.0	V	O	O	X	X	X	X	
		400V: 0.0~510.0	440.0								

Group 02 IM Motor parameter group											
Code	Parameter Name	Range	Default	Unit	Control mode						Attribute
					V/F	V/F+PG	SLV	SV	PM SV	PM SLV	
02-00	No-Load Current of motor1	0.01~600.00	-	A	O	X	X	X	X	X	
02-01	Rated current of motor1	Modes of V/F, V/F+PG are 10%~200% of inverter's rated current. Modes of SLV, SV are 25%~200% of inverter's rated current.	-	A	O	O	O	O	X	X	
02-02	Retain										
02-03	Rated rotation speed of motor1	0~60000	-	Rpm	O	O	O	O	X	X	
02-04	Rated voltage of motor1	200V: 50.0~240.0	220.0	V	O	O	O	O	X	X	
		400V: 100.0~480.0	440.0								
02-05	Rated power of motor1	0.01~600.00	-	kW	O	O	O	O	X	X	
02-06	Rated frequency of motor1	10.0~400.0 10.0~1200.0 (when 00-31 = 1)	60.0	Hz	O	O	O	O	X	X	
02-07	Poles of motor 1	2,4,6,8	4	-	O	O	O	O	X	X	
02-08	Retain										
02-09	Excitation current of motor 1	10.0~100.0	-	%	X	X	O	O	X	X	
02-10	Core saturation coefficient 1 of motor 1	0~100	-	%	X	X	O	O	X	X	
02-11	Core saturation coefficient 2 of motor 1	0~100	-	%	X	X	O	O	X	X	
02-12	Core saturation coefficient 3 of motor 1	80~300	-	%	X	X	O	O	X	X	
02-13	Core loss of motor 1	0.0~15.0	-	%	O	O	X	X	X	X	
02-14	Retain										
02-15	Resistance between wires of motor 1	0.001~60.000	-	Ω	O	O	O	O	X	X	
02-16	Rotor resistance of motor 1	0.001~60.000	-	Ω	X	X	O	O	X	X	
02-17	Leakage inductance of motor 1	0.01~200.00	-	mH	X	X	O	O	X	X	
02-18	Mutual inductance of motor 1	0.1~6553.5	-	mH	X	X	O	O	X	X	
02-19	No-Load Voltage of motor 1	200V: 50~240	-	V	X	X	O	O	X	X	
		400V: 100~480	-								
02-20	No-Load Current of motor2	0.01~600.00	-	A	O	X	X	X	X	X	
02-21	Rated current of motor 2	10%~200% of inverter's rated current	-	A	O	O	O	O	X	X	
02-22	Rated rotation speed of motor 2	0~60000	-	Rpm	O	O	O	O	X	X	
02-23	Rated voltage of motor 2	200V: 50.0~240.0	220.0	V	O	O	O	O	X	X	
		400V: 100.0~480.0	440.0								
02-24	Rated power of motor 2	0.01~600.00	-	kW	O	O	O	O	X	X	

Code	Parameter Name	Range	Default	Unit	Control mode						Attribute
					V/F	V/F+PG	SLV	SV	PM SV	PM SLV	
02-25	Rated frequency of motor 2	10.0~400.0 10.0~1200.0 (when 00-31 = 1)	60.0	Hz	O	O	O	O	X	X	
02-26	Poles of motor 2	2,4,6,8	4	-	O	O	O	O	X	X	
02-27		Retain									
02-28		Retain									
02-29		Retain									
02-30		Retain									
02-31		Retain									
02-32	Resistnce between wires of motor 2	0.001~60.000	-	Ω	O	O	O	O	X	X	
02-33		Retain									
02-34		Retain									
02-35		Retain									
02-36		Retain									

Group 03 External terminal digital signal input (output) function group											
Code	Parameter Name	Range	Default	Unit	Control mode						Attribute
					V/F	V/F+PG	SLV	SV	PM SV	PM SLV	
03-00	Multi-function terminal Function setting-S1	0: 2-Wire sequence (ON : Forward run command).	0	-	O	O	O	O	O	O	
03-01	Multi-function terminal Function setting-S2	1: 2-Wire sequence (ON : Reverse run command).	1	-	O	O	O	O	O	O	
03-02	Multi-function terminal Function setting-S3	2: Multi-speed/position setting command 1	8	-	O	O	O	O	O	O	
03-03	Multi-function terminal Function setting-S4	3: Multi-speed/position setting command 2	9	-	O	O	O	O	O	O	
03-04	Multi-function terminal Function setting-S5	4: Multi-speed/position setting command 3	2	-	O	O	O	O	O	O	
03-05	Multi-function terminal Function setting-S6	5: Multi-speed/position setting command 4	17	-	O	O	O	O	O	O	
03-06	Multi-function terminal Function setting-S7	6 : Forward jog run command 7 : Reverse jog run command 8 : UP frequency increasing command		Two-wire type:29 Three-wire type:26	O	O	O	O	O	O	
03-07	Multi-function terminal Function setting-S8	9: DOWN frequency decreasing command 10: Acceleration/deceleration setting command 1 11: Inhibit Acceleration/deceleration Command 12: Retain 13: Retain 14: Emergency stop	15	-	O	O	O	O	O	O	

Group 03 External terminal digital signal input (output) function group

Code	Parameter Name	Range	Default	Unit	Control mode						Attribute
					V/F	V/F +PG	SLV	SV	PM SV	PM SLV	
		(decelerate to zero and stop) 15: External Baseblock Command(rotation freely to stop) 16 : PID control disable 17: Fault reset (RESET) 18: Retain 19: Speed Search 1(from the maximum frequency) 20: Manual energy saving function 21: PID integral reset 22 : Retain 23 : Retain 24: PLC input 25: External fault 26: 3-Wire sequence (Forward/Reverse command). 27: Local/Remote selection 28: Remote mode selection 29: Jog frequency selection 30: Acceleration/deceleration setting command 2 31: Inverter overheating warning 32: Sync command 33: DC braking 34: Speed Search 2 (from the frequency command) 35: Timing function input 36: PID Soft start invalid 37: Traversing operation 38 : Upper Deviation of traverse operation 39 : Lower Deviation of traverse operation 40: Switching between motor 1/motor 2 41: Retain 42: PG invalid 43: PG integral reset 44: Mode switching between speed and torque 45: Negative torque command 46 : Zero-Servo Command 47: Fire Mode 48: KEB acceleration 49:Parameters writing allowable									

Group 03 External terminal digital signal input (output) function group

Code	Parameter Name	Range	Default	Unit	Control mode						Attribute
					V/F	V/F +PG	SLV	SV	PM SV	PM SLV	
		50 : Unattended Start Protection (USP) 51: Mode switching between speed and position									
03-08	(S1~S8)DI Scan time	0: Scan time 4ms 1: Scan time 8ms	1	-	○	○	○	○	○	○	
03-09	Multi-function terminal S1-S4 type selection	xxx0b: S1 A contact xxx1b: S1 B contact	0000b	-	○	○	○	○	○	○	
		xx0xb: S2 A contact xx1xb: S2 B contact									
		x0xxb: S3 A contact x1xxb: S3 B contact									
		0xxxb: S4 A contact 1xxxb: S4 B contact									
03-10	Multi-function terminal S5-S8 type selection	xxx0b: S5 A contact xxx1b: S5 B contact	0000b	-	○	○	○	○	○	○	
		xx0xb: S6 A contact xx1xb: S6 B contact									
		x0xxb: S7 A contact x1xxb: S7 B contact									
		0xxxb: S8 A contact 1xxxb: S8 B contact									
03-11	Relay (R1A-R1C) output	0: Durning Running 1: Fault contact output	1	-	○	○	○	○	○	○	
03-12	Relay (R2A-R2C) output	2: Frequency Agree 3: Setting Frequency Agree 4: Frequency detection 1 (> 03-13) 5: Frequency detection 2 (< 03-13) 6: Automatic restart 7: Retain 8: Retain 9: Baseblock 10: Retain 11: Retain 12: Over torque detection 13: Retain 14: Retain 15: Retain 16: Retain 17: Retain 18: PLC status 19: PLC control contact 20: zero speed 21: Inverter Ready 22: Undervoltage Detection 23: Source of operation command	20	-	○	○	○	○	○	○	

Group 03 External terminal digital signal input (output) function group

Code	Parameter Name	Range	Default	Unit	Control mode						Attribute
					V/F	V/F +PG	SLV	SV	PM SV	PM SLV	
		24: Source of frequency command 25: Low torque detection 26: Frequency Reference missing 27: Timing function output 28: Traverse operation UP Status 29 : During Traverse operation status 30 : Motor 2 Selection 31 : Zero Servo Completed 32: Communication control contacts									
03-13	Frequency detection Level	0.0~400.0 0.0~1200.0 (when 00-31 = 1)	0.0	Hz	○	○	○	○	○	○	
03-14	Frequency detection width	0.1~25.5	2.0	Hz	○	○	○	○	○	○	
03-15	Retain										
03-16	Retain										
03-17	Retain										
03-18	Retain										
03-19	Relay (R1A-R2C) type	xxx0b: R1 A contact xxx1b: R1 B contact	0000b	-	○	○	○	○	○	○	○
		xx0xb: R2 A contact xx1xb: R2 B contact									
03-20	Retain										
03-21	Retain										
03-22	Retain										
03-23	Retain										
03-24	Retain										
03-25	Retain										
03-26	Retain										
03-27	UP/DOWN frequency maintaining selection	0: maintain UP/DOWN frequency when stopping	0	-	○	○	○	○	○	○	○
		1: clear UP/DOWN frequency when stopping									
		2: allow UP/DOWN frequency when stopping									
03-28	Optocoupler output	Range and definition are the same as those of 03-11, 03-12	0	-	○	○	○	○	○	○	
03-29	optocoupler output selection	xxx0b: optocoupler A contact xxx1b: optocoupler B contact	0000b	-	○	○	○	○	○	○	
03-30	Function setting of pulse input	0: Frequency command	0	-	○	○	○	○	○	○	○
		1: PID feedback									
		2: PID target value									
		3: Retain									

Group 03 External terminal digital signal input (output) function group

Code	Parameter Name	Range	Default	Unit	Control mode						Attribute
					V/F	V/F +PG	SLV	SV	PM SV	PM SLV	
03-31	Scale of pulse input	50~32000	1000	Hz	○	○	○	○	○	○	*1
03-32	Gain of pulse input	0.0~1000.0	100	%	○	○	○	○	○	○	*1
03-33	Bias voltage of pulse input	-100.0~100.0	0.0	%	○	○	○	○	○	○	*1
03-34	Filter time of pulse input	0.00~2.00	0.1	Sec	○	○	○	○	○	○	*1
03-35	Function setting of pulse output	1: Frequency command	2	-	○	○	○	○	○	○	*1
		2: Output frequency									
		3: Output frequency after soft-start									
		4: motor speed									
		5: PID feedback									
		6: PID input									
		7: PG output									
03-36	Scale of pulse output	1~32000	1000	Hz	○	○	○	○	○	○	*1
03-37	Timer ON delay (DIO)	0.0~6000.0	0.0	s	○	○	○	○	○	○	
03-38	Timer OFFdelay (DIO)	0.0~6000.0	0.0	s	○	○	○	○	○	○	

Group 04 External terminal analog signal input(output) function group

Code	Parameter Name	Range	Default	Unit	Control mode						Attribute
					V/F	V/F +PG	SLV	SV	PM SV	PM SLV	
04-00	AI input signal type	0: AI1:0~10V AI2: 0~10V	1	-	O	O	O	O	O	O	
		1: AI1:0~10V AI2: 4~20mA									
		2: AI1: -10~10V AI2: 0~10V									
		3: AI1: -10~10V AI2: 4~20mA									
04-01	AI1 signal scanning and filtering time	0.00~2.00	0.03	s	O	O	O	O	O	O	
04-02	AI1 gain value	0.0~1000.0	100.0	%	O	O	O	O	O	O	*1
04-03	AI1 bias voltage value	-100.0~100.0	0	%	O	O	O	O	O	O	*1
04-04	Retain										
04-05	AI2 function setting	0: Auxiliary Frequency	10	-	O	O	O	O	O	O	
		1: Frequency Reference Gain									
		2: Frequency Reference Bias									
		3: Output Voltage Bias									
		4: Coefficient of acceleration and deceleration reduction									
		5: DC braking current									
		6: Over-torque detection level									
		7: Stall prevention Level During Running									
		8: Frequency lower limit									
		9: Jump frequency 4									
		10: Added to AI1									
		11: Positive torque limit									
		12: Negative torque limit									
		13: Regenerative Torque Limit									
		14: Positive / negative torque limit									
		15: Torque Reference/Torque Limit (in speed control)									
		16: Torque compensation									
17: No function											
04-06	AI2 signal scanning and filtering time	0.00~2.00	0.03	s	O	O	O	O	O	O	
04-07	AI2 gain value	0.0~1000.0	100.0	%	O	O	O	O	O	O	*1
04-08	AI2 bias voltage value	-100.0~100.0	0	%	O	O	O	O	O	O	*1
04-09	Retain										
04-10	Retain										
04-11	AO1 function setting	0: Output frequency	0	-	O	O	O	O	O	O	
		1: Frequency command									
		2: Output voltage									
		3: DC voltage									
		4: Output current									

Group 04 External terminal analog signal input(output) function group

Code	Parameter Name	Range	Default	Unit	Control mode						Attribute
					V/F	V/F +PG	SLV	SV	PM SV	PM SLV	
		5: Output power									
		6: Motor Speed									
		7: Output power factor									
		8: AI1 input									
		9: AI2 input									
		10: Torque command									
		11: q-axis current									
		12: d-axis current									
		13: Speed deviation									
		14: Retain									
		15: ASR output									
		16: Retain									
		17: q-axis voltage									
		18: d-axis voltage									
		19: Retain									
		20: Retain									
		21: PID input									
		22: PID output									
		23: PID target value									
		24: PID feedback value									
		25: Output frequency of the soft starter									
		26: PG feedback									
		27: PG compensation volume									
04-12	AO1 gain value	0.0~1000.0	100.0	%	<input type="radio"/>	<input type="radio"/>	<input type="radio"/>	<input type="radio"/>	<input type="radio"/>	<input type="radio"/>	*1
04-13	AO1 bias-voltage value	-100.0~100.0	0	%	<input type="radio"/>	<input type="radio"/>	<input type="radio"/>	<input type="radio"/>	<input type="radio"/>	<input type="radio"/>	*1
04-14	Retain										
04-15	Retain										
04-16	AO2 function setting	Range and definition are the same as those of 04-11	3	-	<input type="radio"/>	<input type="radio"/>	<input type="radio"/>	<input type="radio"/>	<input type="radio"/>	<input type="radio"/>	
04-17	AO2 gain value	0.0~1000.0	100.0	%	<input type="radio"/>	<input type="radio"/>	<input type="radio"/>	<input type="radio"/>	<input type="radio"/>	<input type="radio"/>	*1
04-18	AO2 bias-voltage value	-100.0~100.0	0	%	<input type="radio"/>	<input type="radio"/>	<input type="radio"/>	<input type="radio"/>	<input type="radio"/>	<input type="radio"/>	*1

Group 05 Multi-Speed Group											
Code	Parameter Name	Range	Default	Unit	Control mode						Attribute
					V/F	V/F+PG	SLV	SV	PM SV	PM SLV	
05-00	Acceleration and deceleration selection of multi-speed	0: acceleration time is set by deceleration time 1~4	0	-	○	○	○	○	○	○	
		1:Acceleration and deceleration time setting respetively									
05-01	Frequency setting of speed-stage 0	0.00~400.00 0.0~1200.0 (when 00-31 = 1)	5.00	Hz	○	○	○	○	○	○	*1
05-02	Retain										
05-03	Retain										
05-04	Retain										
05-05	Retain										
05-06	Retain										
05-07	Retain										
05-08	Retain										
05-09	Retain										
05-10	Retain										
05-11	Retain										
05-12	Retain										
05-13	Retain										
05-14	Retain										
05-15	Retain										
05-16	Retain										
05-17	Acceleration time setting of multi speed 0	0.1~6000.0	10.0	s	○	○	○	○	○	○	
05-18	Deceleration time setting of multi speed 0	0.1~6000.0	10.0	s	○	○	○	○	○	○	
05-19	Acceleration time setting of multi speed 1	0.1~6000.0	10.0	s	○	○	○	○	○	○	
05-20	Deceleration time setting of multi speed 1	0.1~6000.0	10.0	s	○	○	○	○	○	○	
05-21	Acceleration time setting of multi speed 2	0.1~6000.0	10.0	s	○	○	○	○	○	○	
05-22	Deceleration time setting of multi speed 2	0.1~6000.0	10.0	s	○	○	○	○	○	○	
05-23	Acceleration time setting of multi speed 3	0.1~6000.0	10.0	s	○	○	○	○	○	○	
05-24	Deceleration time setting of multi speed 3	0.1~6000.0	10.0	s	○	○	○	○	○	○	
05-25	Acceleration time setting of multi speed 4	0.1~6000.0	10.0	s	○	○	○	○	○	○	
05-26	Deceleration time setting of multi speed 4	0.1~6000.0	10.0	s	○	○	○	○	○	○	
05-27	Acceleration time setting of multi speed 5	0.1~6000.0	10.0	s	○	○	○	○	○	○	
05-28	Deceleration time setting of multi speed 5	0.1~6000.0	10.0	s	○	○	○	○	○	○	
05-29	Acceleration time	0.1~6000.0	10.0	s	○	○	○	○	○	○	

Group 05 Multi-Speed Group											
Code	Parameter Name	Range	Default	Unit	Control mode						Attribute
					V/F	V/F+PG	SLV	SV	PM SV	PM SLV	
	setting of multi speed 6										
05-30	Deceleration time setting of multi speed 6	0.1~6000.0	10.0	s	O	O	O	O	O	O	
05-31	Acceleration time setting of multi speed 7	0.1~6000.0	10.0	s	O	O	O	O	O	O	
05-32	Deceleration time setting of multi speed 7	0.1~6000.0	10.0	s	O	O	O	O	O	O	
05-33	Acceleration time setting of multi speed 8	0.1~6000.0	10.0	s	O	O	O	O	O	O	
05-34	Deceleration time setting of multi speed 8	0.1~6000.0	10.0	s	O	O	O	O	O	O	
05-35	Acceleration time setting of multi speed 9	0.1~6000.0	10.0	s	O	O	O	O	O	O	
05-36	Deceleration time setting of multi speed 9	0.1~6000.0	10.0	s	O	O	O	O	O	O	
05-37	Acceleration time setting of multi speed 10	0.1~6000.0	10.0	s	O	O	O	O	O	O	
05-38	Deceleration time setting of multi speed 10	0.1~6000.0	10.0	s	O	O	O	O	O	O	
05-39	Acceleration time setting of multi speed 11	0.1~6000.0	10.0	s	O	O	O	O	O	O	
05-40	Deceleration time setting of multi speed 11	0.1~6000.0	10.0	s	O	O	O	O	O	O	
05-41	Acceleration time setting of multi speed 12	0.1~6000.0	10.0	s	O	O	O	O	O	O	
05-42	Deceleration time setting of multi speed 12	0.1~6000.0	10.0	s	O	O	O	O	O	O	
05-43	Acceleration time setting of multi speed 13	0.1~6000.0	10.0	s	O	O	O	O	O	O	
05-44	Deceleration time setting of multi speed 13	0.1~6000.0	10.0	s	O	O	O	O	O	O	
05-45	Acceleration time setting of multi speed 14	0.1~6000.0	10.0	s	O	O	O	O	O	O	
05-46	Deceleration time setting of multi speed 14	0.1~6000.0	10.0	s	O	O	O	O	O	O	
05-47	Acceleration time setting of multi speed 15	0.1~6000.0	10.0	s	O	O	O	O	O	O	

Group 05 Multi-Speed Group											
Code	Parameter Name	Range	Default	Unit	Control mode						Attribute
					V/F	V/F+PG	SLV	SV	PM SV	PM SLV	
05-48	Deceleration time setting of multi speed 15	0.1~6000.0	10.0	s	O	O	O	O	O	O	

Group 06 Automatic Programm Operation Function Group											
Code	Parameter Name	Range	Default	Unit	Control mode						Attribute
					V/F	V/F+PG	SLV	SV	PM SV	PM SLV	
06-00	Automatic operation mode selection	0: invalid	0	-	O	O	O	X	O	X	
		1: Execute a single cycle operation mode. Restart speed is based on the previous stopped speed.									
		2: Execute continuous cycle operation mode. Restart speed is based on the previous stopped speed.									
		3: After the completion of a single cycle, the on-going operation speed is based on the speed of the last stage. Restart speed is based on the previous stopped speed.									
		4: Execute a single cycle operation mode. Restart speed will be based on the speed of stage 1.									
		5: Execute continuous cycle operation mode. Restart speed will be based on the speed of stage 1.									
		6: After the completion of a single cycle, the on-going operation speed is based on the speed of the last stage. Restart speed is based on the previous stopped speed.									
06-01	Frequency setting of speed-stage 1	0.00~400.00 0.0~1200.0 (when 00-31 = 1)	5.00	Hz	O	O	O	O	O	O	*1
06-02	Frequency setting of speed-stage 2	0.00~400.00 0.0~1200.0 (when 00-31 = 1)	10.00	Hz	O	O	O	O	O	O	*1
06-03	Frequency setting of speed-stage 3	0.00~400.00 0.0~1200.0 (when 00-31 = 1)	20.00	Hz	O	O	O	O	O	O	*1
06-04	Frequency setting of speed-stage 4	0.00~400.00 0.0~1200.0 (when 00-31 = 1)	30.00	Hz	O	O	O	O	O	O	*1
06-05	Frequency setting of speed-stage 5	0.00~400.00 0.0~1200.0 (when 00-31 = 1)	40.00	Hz	O	O	O	O	O	O	*1

Group 06 Automatic Programm Operation Function Group

Code	Parameter Name	Range	Default	Unit	Control mode						Attribute
					V/F	V/F +PG	SLV	SV	PM SV	PM SLV	
06-06	Frequency setting of speed-stage 6	0.00~400.00 0.0~1200.0 (when 00-31 = 1)	50.00	Hz	O	O	O	O	O	O	*1
06-07	Frequency setting of speed-stage 7	0.00~400.00 0.0~1200.0 (when 00-31 = 1)	50.00	Hz	O	O	O	O	O	O	*1
06-08	Frequency setting of speed-stage 8	0.00~400.00 0.0~1200.0 (when 00-31 = 1)	5.00	Hz	O	O	O	O	O	O	*1
06-09	Frequency setting of speed-stage 9	0.00~400.00 0.0~1200.0 (when 00-31 = 1)	5.00	Hz	O	O	O	O	O	O	*1
06-10	Frequency setting of speed-stage 10	0.00~400.00 0.0~1200.0 (when 00-31 = 1)	5.00	Hz	O	O	O	O	O	O	*1
06-11	Frequency setting of speed-stage 11	0.00~400.00 0.0~1200.0 (when 00-31 = 1)	5.00	Hz	O	O	O	O	O	O	*1
06-12	Frequency setting of speed-stage12	0.00~400.00 0.0~1200.0 (when 00-31 = 1)	5.00	Hz	O	O	O	O	O	O	*1
06-13	Frequency setting of speed-stage 13	0.00~400.00 0.0~1200.0 (when 00-31 = 1)	5.00	Hz	O	O	O	O	O	O	*1
06-14	Frequency setting of speed-stage 14	0.00~400.00 0.0~1200.0 (when 00-31 = 1)	5.00	Hz	O	O	O	O	O	O	*1
06-15	Frequency setting of speed-stage 15	0.00~400.00 0.0~1200.0 (when 00-31 = 1)	5.00	Hz	O	O	O	O	O	O	*1
06-16	Operation time setting of speed-stage 0	0.0~6000.0	0.0	s	O	O	O	X	X	O	*1
06-17	Operation time setting of speed-stage 1	0.0~6000.0	0.0	s	O	O	O	X	X	O	*1
06-18	Operation time setting of speed-stage 2	0.0~6000.0	0.0	s	O	O	O	X	X	O	*1
06-19	Operation time setting of speed-stage 3	0.0~6000.0	0.0	s	O	O	O	X	X	O	*1
06-20	Operation time setting of speed-stage 4	0.0~6000.0	0.0	s	O	O	O	X	X	O	*1
06-21	Operation time setting of speed-stage 5	0.0~6000.0	0.0	s	O	O	O	X	X	O	*1
06-22	Operation time setting of speed-stage 6	0.0~6000.0	0.0	s	O	O	O	X	X	O	*1
06-23	Operation time setting of speed-stage 7	0.0~6000.0	0.0	s	O	O	O	X	X	O	*1
06-24	Operation time setting of speed-stage 8	0.0~6000.0	0.0	s	O	O	O	X	X	O	*1
06-25	Operation time setting of speed-stage 9	0.0~6000.0	0.0	s	O	O	O	X	X	O	*1
06-26	Operation time setting of speed-stage 10	0.0~6000.0	0.0	s	O	O	O	X	X	O	*1
06-27	Operation time setting of speed-stage 11	0.0~6000.0	0.0	s	O	O	O	X	X	O	*1
06-28	Operation time setting of speed-stage 12	0.0~6000.0	0.0	s	O	O	O	X	X	O	*1
06-29	Operation time setting of speed-stage 13	0.0~6000.0	0.0	s	O	O	O	X	X	O	*1

Group 06 Automatic Programm Operation Function Group

Code	Parameter Name	Range	Default	Unit	Control mode						Attribute
					V/F	V/F+PG	SLV	SV	PM SV	PM SLV	
06-30	Operation time setting of speed-stage 14	0.0~6000.0	0.0	s	O	O	O	X	X	O	*1
06-31	Operation time setting of speed-stage 15	0.0~6000.0	0.0	s	O	O	O	X	X	O	*1
06-32	Operation direction selection of speed-stage 0	0: Stop 1: Forward 2: Reversal	0	-	O	O	O	X	X	O	
06-33	Operation direction selection of speed-stage 1	0: Stop 1: Forward 2: Reversal	0	-	O	O	O	X	X	O	
06-34	Operation direction selection of speed-stage2	0: Stop 1: Forward 2: Reversal	0	-	O	O	O	X	X	O	
06-35	Operation direction selection of speed-stage 3	0: Stop 1: Forward 2: Reversal	0	-	O	O	O	X	X	O	
06-36	Operation direction selection of speed-stage 4	0: Stop 1: Forward 2: Reversal	0	-	O	O	O	X	X	O	
06-37	Operation direction selection of speed-stage 5	0: Stop 1: Forward 2: Reversal	0	-	O	O	O	X	X	O	
06-38	Operation direction selection of speed-stage 6	0: Stop 1: Forward 2: Reversal	0	-	O	O	O	X	X	O	
06-39	Operation direction selection of speed-stage 7	0: Stop 1: Forward 2: Reversal	0	-	O	O	O	X	X	O	
06-40	Operation direction selection of speed-stage 8	0: Stop 1: Forward 2: Reversal	0	-	O	O	O	X	X	O	
06-41	Operation direction selection of speed-stage 9	0: Stop 1: Forward 2: Reversal	0	-	O	O	O	X	X	O	
06-42	Operation direction selection of speed-stage 10	0: Stop 1: Forward 2: Reversal	0	-	O	O	O	X	X	O	
06-43	Operation direction selection of speed-stage 11	0: Stop 1: Forward 2: Reversal	0	-	O	O	O	X	X	O	
06-44	Operation direction selection of speed-stage 12	0: Stop 1: Forward 2: Reversal	0	-	O	O	O	X	X	O	
06-45	Operation direction selection of speed-stage13	0: Stop 1: Forward 2: Reversal	0	-	O	O	O	X	X	O	
06-46	Operation direction selection of	0: Stop 1: Forward 2: Reversal	0	-	O	O	O	X	X	O	

Group 06 Automatic Programm Operation Function Group

Code	Parameter Name	Range	Default	Unit	Control mode						Attribute
					V/F	V/F+PG	SLV	SV	PM SV	PM SLV	
	speed-stage 14										
06-47	Operation direction selection of speed-stage 15	0: Stop 1: Forward 2: Reversal	0	-	O	O	O	X	X	O	

Group 07 Start /Stop Function Group

Code	Parameter Name	Range	Default	Unit	Control mode						Attribute
					V/F	V/F+PG	SLV	SV	PM SV	PM SLV	
07-00	Momentary stop and restart selection	0:invalid 1:valid	0	-	O	O	O	O	O	O	
07-01	Restart time of automatic reset	0~7200	0	s	O	O	O	O	O	O	
07-02	Times of automatic reset	0~10	0	-	O	O	O	O	O	O	
07-03	Retain										
07-04	Retain										
07-05	Retain										
07-06	DC Injection Braking Starting Frequency	0.0~10.0	0.5	Hz	O	O	O	O	X	X	
07-07	DC Injection Braking Current	0~100	50	%	O	O	O	O	X	X	
07-08	DC Injection Braking Time at Stop	0.00~10.00	0.50	s	O	O	O	O	X	X	
07-09	Stop mode selection	0: Deceleration to stop 1: Coast to stop 2: DC braking stop in all fields 3: Coast to stop with timer	0	-	O	O	O	O	O	O	
07-10	Retain										
07-11	Retain										
07-12	Retain										
07-13	Low voltage Detection Level	200V: 150~210 400V: 300~420	190 380	V	O	O	O	O	O	O	
07-14	Maximum pre-excitation time	0.00~10.00	2.00	s	X	X	O	X	X	X	
07-15	Pre-excitation Level	100~200	100	%	X	X	O	X	X	X	
07-16	DC Injection Braking Time at Start	0.00~10.00	0.00	s	O	O	O	O	O	O	
07-17	Retain										
07-18	Minimum Base block Time	0.1~5.0	-	Sec	O	O	O	X	X	O	
07-19	Speed Direction Search Operating Current	0~100	50	%	O	X	O	X	X	O	
07-20	Speed Search Operating Current	0~100	20	%	O	X	O	X	X	O	
07-21	Integral time of speed	0.1~10.0	2.0	Sec	O	X	O	X	X	O	

Group 07 Start /Stop Function Group											
Code	Parameter Name	Range	Default	Unit	Control mode						Attribute
					V/F	V/F+PG	SLV	SV	PM SV	PM SLV	
	searching										
07-22	Delay time of speed searching	0.0~20.0	0.2	Sec	O	O	O	O	O	O	
07-23	Voltage Recovery Time	0.1~5.0	2.0	Sec	O	O	O	O	O	O	
07-24	Bidirection Speed Search Selection	0:invalid	0	-	O	O	O	X	X	O	
		1:valid									
07-25	Low voltage Detection Time	0.00~1.00	0.00	Sec	O	O	O	O	O	O	
07-26	Mechanical braking selection	0:invalid	0	-	X	X	O	X	X	O	
		1:valid									

Group 08 Protection Function Group											
Code	Parameter Name	Range	Default	Unit	Control mode						Attribute
					V/F	V/F+PG	SLV	SV	PM SV	PM SLV	
08-00	Stall prevention function	xxx0b: Stall prevention is valid in acceleration.	0000b	-	O	O	O	O	X	O	
		xxx1b: Stall prevention is invalid in acceleration.									
		xx0xb: Stall prevention is valid in deceleration.									
		xx1xb: Stall prevention is invalid in deceleration.									
		x0xxb: Stall prevention is valid in operation									
		x1xxb: Stall prevention is invalid in operation									
		0xxxb: Stall prevention in operation is based on deceleration time of speed-stage 1.									
		1xxxb: Stall prevention in operation is based on deceleration time of speed-stage 2.									
08-01	Stall prevention level in acceleration	30~200	HD:150 ND:120	%	O	O	O	X	X	O	
08-02	Stall prevention level in deceleration	200V: 330~410	395	V	O	O	O	X	X	O	
		400V: 660~820	790								
08-03	Stall prevention level in operation	30~200	HD:160 ND:120	%	O	O	O	X	X	O	
08-04	Retain										

Code	Parameter Name	Range	Default	Unit	Control mode						Attribute
					V/F	V/F+PG	SLV	SV	PM SV	PM SLV	
08-05	Selection for motor overload protection (OL1)	xxx0b: Motor overload is invalid.	0001b	-	0	0	0	0	0	0	0
		xxx1b: Motor overload is valid.									
		xx0xb: Cold start of motor overload									
		xx1xb: Hot start of motor overload									
		x0xxb: Standard motor									
		x1xxb: Inverter motor									
		0xxxb: Retain									
1xxxb: Retain											
08-06	Start-up mode of overload protection operation (OL1)	0: stop output after overload protection	0	-	0	0	0	0	0	0	0
		1: Continuous operation after overload protection.									
08-07	Retain										
08-08	Automatic voltage regulation (AVR)	0: Valid	0	-	0	0	0	0	0	0	0
		1: Invalid									
08-09	Selection of input phase loss protection	0: Invalid	0	-	0	0	0	0	0	0	0
		1: Valid									
08-10	Selection of output phase loss protection	0: Invalid	0	-	0	0	0	0	0	0	0
		1: Valid									
08-11	Retain										
08-12	Retain										
08-13	Selection of over-torque detection	0: Over-torque detection is invalid.	0	-	0	0	0	0	0	0	0
		1: Start to detect when reaching the set frequency.									
		2: Start to detect when the operation is begun.									
08-14	Selection of over-torque operation	0: Deceleration to stop when over torque is detected.	0	-	0	0	0	0	0	0	0
		1: Display warning when over torque is detected. Go on operation.									
08-15	Level of over-torque detection	0~300	150	%	0	0	0	0	0	0	0
08-16	Time of over-torque detection	0.0~10.0	0.1	Sec	0	0	0	0	0	0	0
08-17	Selection of low-torque detection	0: Low-torque detection is invalid.	0	-	0	0	0	0	0	0	0
		1: Start to detect when reaching the set frequency.									
		2: Start to detect when the operation is begun.									

Code	Parameter Name	Range	Default	Unit	Control mode						Attribute
					V/F	V/F+PG	SLV	SV	PM SV	PM SLV	
08-18	Selection of low-torque operation	0: Deceleration to stop when low torque is detected.	0	-	○	○	○	○	○	○	
		1: Display warning when low torque is detected. Go on operation.									
08-19	Level of low-torque detection	0~300	150	%	○	○	○	○	○	○	
08-20	Time of low-torque detection	0.0~10.0	0.1	Sec	○	○	○	○	○	○	
08-21	Limit of stall prevention in acceleration	0~100	50	%	○	○	○	X	X	○	
08-22	Stall prevention detection time in operation	2~100	100	ms	○	○	○	X	X	○	
08-23	Ground Fault Selection	0: invalid	0	-	○	○	○	○	○	○	
		1: valid									
08-24	External Fault Operation Selection	0: Deceleration to stop	0	-	○	○	○	○	○	○	
		1: Coast to stop									
		2: continuous operation									
08-25	Detection selection of external fault	0: Immediately detect when the power is supplied.	0	-	○	○	○	○	○	○	
		1: Start to detect when the operation is started.									
08-26	Retain										
08-27	Retain										
08-28	Retain										
08-29	Retain										
08-30	Retain										

Group 09 Communication Function Group											
Code	Parameter Name	Range	Default	Unit	Control mode						Attribute
					V/F	V/F+PG	SLV	SV	PM SV	PM SLV	
09-00	INV Communication Station Address	1~31	1	-	○	○	○	○	○	○	*2
09-01	Retain										
09-02	Baud rate setting	0:1200	3	-	○	○	○	○	○	○	*2
		1:2400									
		2:4800									
		3:9600									
		4:19200									

Code	Parameter Name	Range	Default	Unit	Control mode						Attribute
					V/F	V/F+PG	SLV	SV	PM SV	PM SLV	
09-03	Stop bit selection	0: 1 stop bit 1: 2 stop bit	0	-	○	○	○	○	○	○	*2
09-04	Parity selection	0: No Parity 1: even bit 2: odd bit	0	-	○	○	○	○	○	○	*2
09-05	Retain										
09-06	Communication error detection time	0.0~25.5	0.0	S	○	○	○	○	○	○	
09-07	Fault stop selection	0: Deceleration to stop based on deceleration time 1 when communication fault occurs. 1: Coast to stop when communication fault occurs. 2: Deceleration to stop based on deceleration time 2 when communication fault occurs. 3: Keep operating when communication fault occurs.	3	-	○	○	○	○	○	○	
09-08	Retain										
09-09	Waiting time	5~65	5	ms	○	○	○	○	○	○	



Group 10 PID Function Group											
Code	Parameter Name	Range	Default	Unit	Control mode						Attribute
					V/F	V/F+PG	SLV	SV	PM SV	PM SLV	
10-00	PID target value source setting (00-05=5 this parameter is enabled)	1:A11 given 2:A12 given 3:Retain 4:10-02 given	1	-	○	○	○	○	○	○	
10-01	PID feedback value source setting	1:A11 given 2:A12 given 3:Retain	2	-	○	○	○	○	○	○	
10-02	PID target value	0.0~100.0	0.0	%	○	○	○	○	○	○	
10-03	PID control mode	xxx0b: PID invalid xxx1b: PID valid xx0xb: PID positive characteristic xx1xb: PID negative characteristic x0xxb: PID error value of D control x1xxb: PID feedback value of D control 0xxb: PID output 1xxb: PID output + target value	0000b	-	○	○	○	○	○	○	

Group 10 PID Function Group											
Code	Parameter Name	Range	Default	Unit	Control mode						Attribute
					V/F	V/F +PG	SLV	SV	PM SV	PM SLV	
10-04	Feedback gain	0.01~10.00	1.00	-	O	O	O	O	O	O	*1
10-05	Proportional gain (P)	0.00~10.00	1.00	-	O	O	O	O	O	O	*1
10-06	Integral time (I)	0.0~100.0	1.00	s	O	O	O	O	O	O	*1
10-07	Differential time(D)	0.00~10.00	0.00	s	O	O	O	O	O	O	*1
10-08	Retain										
10-09	PID bias voltage	-100.0~100.0	0	%	O	O	O	O	O	O	*1
10-10	PID Primary Delay Time	0.00~10.00	0.00	s	O	O	O	O	O	O	*1
10-11	PID Feedback Loss Detection Selection	0: Invalid	0	-	O	O	O	O	O	O	
		1: Warning									
		2: Fault									
10-12	PID Feedback Loss Detection Level	0~100	0	%	O	O	O	O	O	O	
10-13	PID Feedback Loss Detection Time	0.0~10.0	1.0	s	O	O	O	O	O	O	
10-14	PID integral limit	0.0~100.0	100.0	%	O	O	O	O	O	O	*1
10-15	Retain										
10-16	Retain										
10-17	Start frequency of PID sleep	0.00~180.00	0.00	Hz	O	O	O	O	O	O	
10-18	Delay time of PID sleep	0.0~255.5	0.0	s	O	O	O	O	O	O	
10-19	Frequency of PID waking up	0.00~180.00	0.00	Hz	O	O	O	O	O	O	
10-20	Delay time of PID waking up	0.0~255.5	0.0	s	O	O	O	O	O	O	
10-21	Retain										
10-22	Retain										
10-23	PID limit	0.00~100.0	100.0	%	O	O	O	O	O	O	*1
10-24	PID output gain	0.0~25.0	1.0	-	O	O	O	O	O	O	
10-25	PID reversal output selection	0: No allowing reversal output	0	-	O	O	O	O	O	O	
		1: Allow reversal output									
10-26	PID target acceleration/deceleration time	0.0~25.5	0.0	s	O	O	O	O	O	O	
10-27	PID feedback display bias	-99.99~99.99	0.00	-	O	O	O	O	O	O	
10-28	PID feedback display gain	0.00~99.99	1.00	-	O	O	O	O	O	O	
10-29	PID sleep selection	0: invalid	1	-	O	O	O	O	O	O	
		1: valid									
		2: set by DI									

Group 11 Auxiliary Function Group											
Code	Parameter Name	Range	Default	Unit	Control mode						Attribute
					V/F	V/F+PG	SLV	SV	PM SV	PM SLV	
11-00	Direction Lock Selection	0: Allow forward and reverse rotation	0	-	O	O	O	O	O	O	
		1: Only allow forward rotation									
		2: Only allow reverse rotation									
11-01	Carrier frequency	【0】 : carrier output frequency tuning 【1】 : Retain 【2~16】 KHz	Determined by horse power (HP) value	-	O	O	O	O	O	O	
11-02	Soft PWM Function Selection	0: invalid	0	-	O	O	O	O	O	O	
		1: valid									
11-03	Automatic carrier lowering selection	0: invalid	0	-	O	O	X	X	X	X	
		1: valid									
11-04	S curve time setting at the start of acceleration	0.00~2.50	0.00	s	O	O	O	O	O	O	
11-05	S curve time setting at the end of acceleration	0.00~2.50	0.00	s	O	O	O	O	O	O	
11-06	S curve time setting at the start of deceleration	0.00~2.50	0.00	s	O	O	O	O	O	O	
11-07	S curve time setting at the end of deceleration	0.00~2.50	0.00	s	O	O	O	O	O	O	
11-08	Jump frequency 1	0.0~400.0 0.0~1200.0 (when 00-31 = 1)	0.0	Hz	O	O	O	O	O	O	
11-09	Jump frequency 2	0.0~400.0 0.0~1200.0 (when 00-31 = 1)	0.0	Hz	O	O	O	O	O	O	
11-10	Jump frequency 3	0.0~400.0 0.0~1200.0 (when 00-31 = 1)	0.0	Hz	O	O	O	O	O	O	
11-11	Jump frequency width	0.0~25.5	1.0	Hz	O	O	O	O	O	O	
11-12	Manual energy saving gain	0~100	80	%	O	O	X	X	X	X	
11-13	Retain										
11-14	Retain										
11-15	Retain										
11-16	Retain										
11-17	Retain										
11-18	Manual energy saving frequency	0.00~400.00 0.0~1200.0 (when 00-31 = 1)	0.00	Hz	O	X	X	X	X	X	
11-19	Automatic energy saving function	0: Automatic energy saving is invalid	0	-	O	X	X	X	X	X	
		1: Automatic energy saving is valid									
11-20	Filter time of automatic energy saving	0~200	140	ms	O	X	X	X	X	X	
11-21	Voltage upper limit of energy saving tuning	0~100	100	%	O	X	X	X	X	X	

Group 11 Auxiliary Function Group												
Code	Parameter Name	Range	Default	Unit	Control mode						Attribute	
					V/F	V/F+PG	SLV	SV	PM SV	PM SLV		
11-22	Adjustment time of automatic energy saving	0~5000	20	ms	O	X	X	X	X	X	*1	
11-23	Detection level of automatic energy saving	0~100	10	%	O	X	X	X	X	X		
11-24	Coefficient of automatic energy saving	0.00~655.35	-	-	O	X	X	X	X	X		
11-25	Retain											
11-26	Retain											
11-27	Retain											
11-28	Retain											
11-29	Auto De-rating Selection	0: invalid 1: valid	0	-	O	X	X	X	X	X		
11-30	Variable Carrier Frequency Max. Limit	2~16	-	KHz	O	O	X	X	X	X		
11-31	Variable Carrier Frequency Min. Limit	2~16	-	KHz	O	O	X	X	X	X		
11-32	Variable Carrier Frequency Proportional Gain	00~99	00	-	O	O	X	X	X	X		
11-33	DC Voltage Filter Rise Amount	0.1~10.0	0.1	Vdc	O	O	X	X	X	X	*1	
11-34	DC Voltage Filter Fall Amount	0.1~10.0	5.0	Vdc	O	O	X	X	X	X	*1	
11-35	DC Voltage Filter Deadband Level	0.0~99.0	10.0	Vdc	O	O	X	X	X	X	*1	
11-36	Frequency gain of OV prevention	0.000~1.000	0.050	-	O	O	X	X	X	X	*1	
11-37	Frequency limit of OV prevention	0.00~10.00	5.00	Hz	O	O	X	X	X	X		
11-38	Deceleration start voltage of OV prevention	200V: 200~400V	300	V	O	O	X	X	X	X		
		400V: 400~800V	700									
11-39	Deceleration stop voltage of OV prevention	220V: 300~400V	350	V	O	O	X	X	X	X		
		440V: 600~800V	750									
11-40	OV prevention Selection	0: invalid 1: valid	0	-	O	O	X	X	X	X		

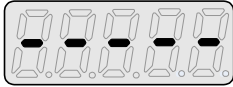
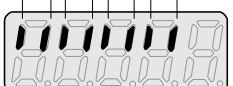
Code	Parameter Name	Range	Default	Unit	Control mode						Attribute
					V/F	V/F+PG	SLV	SV	PM SV	PM SLV	
11-41	Selection of detecting the disappearance of reference frequency	0: When referring to frequency disappears, the deceleration stops	0	-	○	○	○	○	○	○	
		1: When referring to frequency disappears, operation will be based on the proportion of reference frequency x 11-42									
11-42	Disappearance level of reference frequency	0.0~100.0	80.0	%	○	○	○	○	○	○	
11-43	Hold Frequency at Start	0.0~400.0	0.0	Hz	○	○	○	○	○	○	
11-44	Frequency hold Time at Start	0.0~10.0	0.0	s	○	○	○	○	○	○	
11-45	Hold Frequency at Stop	0.0~400.0	0.0	Hz	○	○	○	○	○	○	
11-46	Frequency hold Time at Stop	0.0~10.0	0.0	s	○	○	○	○	○	○	
11-47	KEB deceleration time	0.0~25.5	0.0	s	○	○	○	○	○	○	*1
11-48	KEB detection Level	200V: 190~210	200	V	○	○	○	○	○	○	
		400V: 380~420	400								
11-49	Zero-servo gain	0~50	5	-	X	X	○	○	○	○	
11-50	Zero-servo Count	0~4096	12	-	X	X	○	○	○	○	
11-51	Braking selection of zero speed	0: invalid	0	-	○	X	X	X	X	X	
		1: valid									
11-52	Droop control level	0.0~100.0%	0.0	%	X	X	X	○	○	X	*1
11-53	Droop control delay	0.01~2.00	0.02	s	X	X	X	○	○	X	*1
11-54	Output KWHr initialization	0: don't clear output KWHr	0	-	○	○	○	○	○	○	*1
		1: clear output KWHr									
11-55	STOP key selection	0: Stop key is invalid when the operation command is not provided by operator.	1	-	○	○	○	○	○	○	
		1: Stop key is valid when the operation command is not provided by operator.									
11-56	UP/DOWN selection	0: when operator's UP/DOWN is invalid, it will be valid if press ENTER after frequency modification.	0	-	○	○	○	○	○	○	
		1: when operator's UP/DOWN is valid, it will be valid after frequency modification.									
11-57	Retain										
11-58	Record reference frequency	0: invalid	0	-	○	○	○	○	○	○	*1
		1: valid									

Group 12 Monitoring Function Group												
Code	Parameter Name	Range	Default	Unit	Control mode						Attribute	
					V/F	V/F+PG	SLV	SV	PM SV	PM SLV		
12-00	Display screen selection (LED)	00000~77777 From the leftmost bit, it displays the screen when press DSP key in order. 0:no display 1: Output current 2: Output voltage 3:DC bus voltage 4:heatsink temperature 5:PID feedback 6:AI1 value 7:AI2 value	00000	-								
12-01	PID feedback display mode (LED)	0:Display the feedback value by integer (xxx)	0									
		1: Display the feedback value by the value with one decimal place (xx.x)										
		2: Display the feedback value by the value with two decimal places (x.xx)										
12-02	PID feedback display unit setting (LED)	0:xxxxx (no unit)	0									
		1:xxxPb(pressure)										
		2:xxxFL(flow)										
12-03	Retain											
12-04	Retain											
12-05	Status display of digital input terminal (LED / LCD)	LED display is shown as below no input  correspondences to input and output S1 S2 S3 S4 S5 S6 S7 S8   R1 R2 DO1 LCM display is shown as below	-	-								

Group 12 Monitoring Function Group

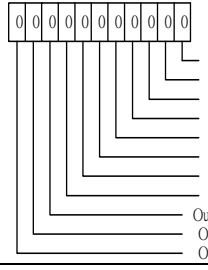
Code	Parameter Name	Range	Default	Unit	Control mode						Attribute
					V/F	V/F+PG	SLV	SV	PM SV	PM SLV	
		 <p>0 : OPEN 1 : CLOSE In u Terminal(S8) In u Terminal(S7) In u Terminal(S6) In u Terminal(S5) In u Terminal(S4) In u Terminal(S3) In u Terminal(S2) In u Terminal(S1) Ou u Terminal(DO1) Ou u Terminal(R2) Ou u Terminal(R1)</p>									
12-06	Retain										
12-07	Retain										
12-08	Retain										
12-09	Retain										
12-10	Retain										
12-11	Output current of current fault	Display the output current of current fault	-	A	<input type="checkbox"/>	<input type="checkbox"/>	<input type="checkbox"/>	<input type="checkbox"/>	<input type="checkbox"/>	<input type="checkbox"/>	
12-12	Output voltage of current fault	Display the output voltage of current fault	-	V	<input type="checkbox"/>	<input type="checkbox"/>	<input type="checkbox"/>	<input type="checkbox"/>	<input type="checkbox"/>	<input type="checkbox"/>	
12-13	Output frequency of current fault	Display the output frequency of current fault	-	Hz	<input type="checkbox"/>	<input type="checkbox"/>	<input type="checkbox"/>	<input type="checkbox"/>	<input type="checkbox"/>	<input type="checkbox"/>	
12-14	DC voltage of current fault	Display the DC voltage of current fault	-	V	<input type="checkbox"/>	<input type="checkbox"/>	<input type="checkbox"/>	<input type="checkbox"/>	<input type="checkbox"/>	<input type="checkbox"/>	
12-15	Frequency command of current fault	Display the frequency command of current fault	-	Hz	<input type="checkbox"/>	<input type="checkbox"/>	<input type="checkbox"/>	<input type="checkbox"/>	<input type="checkbox"/>	<input type="checkbox"/>	
12-16	Frequency command	If LED enters this parameter, it only allows monitoring frequency command.	-	Hz	<input type="checkbox"/>	<input type="checkbox"/>	<input type="checkbox"/>	<input type="checkbox"/>	<input type="checkbox"/>	<input type="checkbox"/>	
12-17	Output frequency	Display the current output frequency	-	Hz	<input type="checkbox"/>	<input type="checkbox"/>	<input type="checkbox"/>	<input type="checkbox"/>	<input type="checkbox"/>	<input type="checkbox"/>	
12-18	Output current	Display the current output current	-	A	<input type="checkbox"/>	<input type="checkbox"/>	<input type="checkbox"/>	<input type="checkbox"/>	<input type="checkbox"/>	<input type="checkbox"/>	
12-19	Output voltage	Display the current output voltage	-	V	<input type="checkbox"/>	<input type="checkbox"/>	<input type="checkbox"/>	<input type="checkbox"/>	<input type="checkbox"/>	<input type="checkbox"/>	
12-20	DC voltage (Vdc)	Display the current DC voltage	-	V	<input type="checkbox"/>	<input type="checkbox"/>	<input type="checkbox"/>	<input type="checkbox"/>	<input type="checkbox"/>	<input type="checkbox"/>	
12-21	Output power(kw)	Display the current output power	-	kW	<input type="checkbox"/>	<input type="checkbox"/>	<input type="checkbox"/>	<input type="checkbox"/>	<input type="checkbox"/>	<input type="checkbox"/>	
12-22	Motor's rotation speed (rpm)	Display motor's current rotation speed in VF/SLV mode Motor's rotation speed = output power x(120/motor's pole number) In PG/SV mode, motor's rotation speed is calculated by feedback frequency.	-	rpm	<input type="checkbox"/>	<input type="checkbox"/>	<input type="checkbox"/>	<input type="checkbox"/>	<input type="checkbox"/>	<input type="checkbox"/>	
12-23	Output power factor (Pfo)	Display the current output power factor	-	-	<input type="checkbox"/>	<input type="checkbox"/>	<input type="checkbox"/>	<input type="checkbox"/>	<input type="checkbox"/>	<input type="checkbox"/>	

Code	Parameter Name	Range	Default	Unit	Control mode						Attribute
					V/F	V/F+PG	SLV	SV	PM SV	PM SLV	
12-24	Control mode	Display control mode 0 : VF 1 : PG 2 : SLV 3 : SV 4 : PSV	-	-	O	O	O	O	O	O	
12-25	AI1 input	Display the current AI1 input (-10V corresponds to -100%, 10V corresponds to 100%,)	-	%	O	O	O	O	O	O	
12-26	AI2 input	Display the current AI2 input (0V or 4mA corresponds to 0%, 10V or 20mA corresponds to 100%)	-	%	O	O	O	O	O	O	
12-27	Torque command	Display the current torque command (100% corresponds to motor torque)	-	%	X	X	O	O	O	O	
12-28	Motor torque current (Iq)	Display the current q-axis current	-	%	X	X	O	O	O	O	
12-29	Motor excitation current (Id)	Display the current d-axis current	-	%	X	X	O	O	O	O	
12-30	ASR deviation	Display deviation of speed controller (speed command - speed feedback) (100% corresponds to the maximum frequency set by 01-02)	-	%	X	O	X	O	O	X	
12-31	ASR filter output	Display output of speed controller (100% corresponds to the maximum frequency set by 01-02)	-	%	X	O	X	O	O	X	
12-32	ASR output	Display output value of speed controller (100% corresponds to the maximum frequency set by 01-02)	-	%	X	O	X	O	O	X	
12-33	PG feedback	Display feedback's speed value of speed controller (100% corresponds to the maximum frequency set by 01-02)	-	%	X	O	X	O	O	X	
12-34	Retain										
12-35	Zero-servo pulse	When display SV position mode, the position error pulse number of the zero speed servo (the pulse number of a circle is four times of set values of 20-27)	-	Pulse	X	X	X	O	O	X	
12-36	PID input	Display input error of the PID	0.01	%	O	O	O	O	O	O	

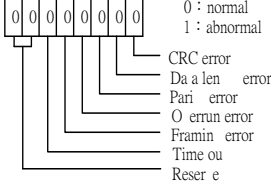
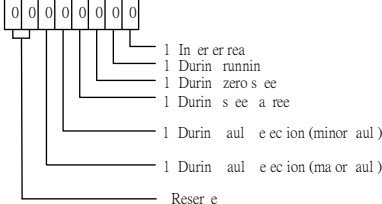
Code	Parameter Name	Range	Default	Unit	Control mode						Attribute	
					V/F	V/F +PG	SLV	SV	PM SV	PM SLV		
		controller (PID target value - PID feedback) (100% corresponds to the maximum frequency set by 01-02 or 01-16)										
12-37	PID output	Display output of the PID controller (100% corresponds to the maximum frequency set by 01-02 or 01-16)	-	%	0	0	0	0	0	0		
12-38	PID setting	Display the target value of the PID controller (100% corresponds to the maximum frequency set by 01-02 or 01-16)	-	%	0	0	0	0	0	0		
12-39	PID feedback	Display the feedback value of the PID controller (100% corresponds to the maximum frequency set by 01-02 or 01-16)	-	%	0	0	0	0	0	0		
12-40	Motor's cumulative output energy	Display motor's cumulative output energy	-	KW Hr	0	0	0	0	0	0		
12-41	Heatsink temperature	Display the heatsink temperature of IGBT temperature.	-	Degree C	0	0	0	0	0	0		
12-42	RS-485 error code	Display the status of RS-485 	-	-	0	0	0	0	0	0		
12-43	Inverter status		-	-	0	0	0	0	0	0		
12-44	Pulse input frequency	Display the frequency value of pulse input	-	Hz	0	0	0	0	0	0		
12-45	Recent fault message	Display current fault message	-	-	0	0	0	0	0	0		
12-46	Previous fault message	Display previous fault message	-	-	0	0	0	0	0	0		
12-47	Previous two fault messages	Display previous two fault messages	-	-	0	0	0	0	0	0		
12-48	Previous three fault messages	Display previous three fault messages	-	-	0	0	0	0	0	0		
12-49	Previous four fault messages	Display previous four fault messages	-	-	0	0	0	0	0	0		
12-50	DIO status of current	Display the DI/DO status of	-	-	0	0	0	0	0	0		

Code	Parameter Name	Range	Default	Unit	Control mode						Attribute	
					V/F	V/F+PG	SLV	SV	PM SV	PM SLV		
	fault	current fault Description is similar to 12-05										
12-51	Inverter status of current fault	Display the inverter status of current fault Description is similar to 12-43	-	-	O	O	O	O	O	O		
12-52	Trip time 1 of current fault	Display the operation time of current fault,12-53 is the days,	-	Hr	O	O	O	O	O	O		
12-53	Trip time 2 of current fault	while 12-52 is the ahemeral hours .	-	day	O	O	O	O	O	O		
12-54	Frequency command of previous fault	Display frequency command of previous fault	-	Hz	O	O	O	O	O	O		
12-55	Output frequency of previous fault	Display output frequency of previous fault	-	Hz	O	O	O	O	O	O		
12-56	Output current of previous fault	Display output current of previous fault	-	A	O	O	O	O	O	O		
12-57	Output voltage of previous fault	Display output voltage of previous fault	-	V	O	O	O	O	O	O		
12-58	DC voltage of previous fault	Display DC voltage of previous fault	-	V	O	O	O	O	O	O		
12-59	DIO status of previous fault	Display DI/DO status of previous fault Description is similar to 12-05	-	-	O	O	O	O	O	O		
12-60	Inverter status of previous fault	Display inverter status of previous fault Description is similar to 12-43	-	-	O	O	O	O	O	O		
12-61	Trip time 1 of last fault	Display the operation time of last time's fault,12-62 is the days,	-	Hr	O	O	O	O	O	O		
12-62	Trip time 2 of last fault	while 12-61 is the ahemeral hours .	-	day	O	O	O	O	O	O		
12-63	Recent warning messages	Display the recent warning messages	-	-	O	O	O	O	O	O		
12-64	Previous warning message	Display the previous warning message	-	-	O	O	O	O	O	O		

Group 13 Maintenance Function Group											
Code	Parameter Name	Range	Default	Unit	Control mode						Attribute
					V/F	V/F +PG	SLV	SV	PM SV	PM SLV	
13-00	Inverter Capacity Selection	----	-	-	0	0	0	0	0	0	*4
13-01	Software Version	----	-	-	0	0	0	0	0	0	*4
13-02	Retain										
13-03	Cumulative operation hours 1	0~23	-	hr	0	0	0	0	0	0	*4
13-04	Cumulative operation hours 2	0~65535	-	day	0	0	0	0	0	0	*4
13-05	Selection of cumulative operation time	0: Cumulative time in power on 1: Cumulative time in operation	0	-	0	0	0	0	0	0	*1
13-06	Parameters locked	0: Parameters out of 13-06 are unwritable. 1: Retain 2: all parameters are writable	2	-	0	0	0	0	0	0	*1
13-07	Parameter password function	0~9999	0	-	0	0	0	0	0	0	
13-08	Restore factory setting	0: no initialization 2: 2 wire initialization(230/460V) 3: 3 wire initialization(230/460V) 4: 2 wire initialization(200/415V) 5: 3 wire initialization(200/415V) 6: 2 wire initialization(200/380V) 7: 2 wire initialization(200/380V) Others: Retain	0	-	0	0	0	0	0	0	
13-09	Fault history clearance function	0: no clearing fault history 1: Clear fault history	0	-	0	0	0	0	0	0	*1

Group 14 PLC Setting Group

Code	Parameter Name	Range	Default	Unit	Control mode						Attribute
					V/F	V/F +PG	SLV	SV	PM SV	PM SLV	
14-00	T1 set value 1	0~9999	0	-	○	○	○	○	○	○	
14-01	T1 set value 2 (mode 7)	0~9999	0	-	○	○	○	○	○	○	
14-02	T2 set value 1	0~9999	0	-	○	○	○	○	○	○	
14-03	T2 set value 2 (mode 7)	0~9999	0	-	○	○	○	○	○	○	
14-04	T3 set value 1	0~9999	0	-	○	○	○	○	○	○	
14-05	T3 set value 2 (mode 7)	0~9999	0	-	○	○	○	○	○	○	
14-06	T4 set value 1	0~9999	0	-	○	○	○	○	○	○	
14-07	T4 set value 2 (mode 7)	0~9999	0	-	○	○	○	○	○	○	
14-08	T5 set value 1	0~9999	0	-	○	○	○	○	○	○	
14-09	T5 set value 2 (mode 7)	0~9999	0	-	○	○	○	○	○	○	
14-10	T6 set value 1	0~9999	0	-	○	○	○	○	○	○	
14-11	T6 set value 2 (mode 7)	0~9999	0	-	○	○	○	○	○	○	
14-12	T7 set value 1	0~9999	0	-	○	○	○	○	○	○	
14-13	T7 set value 2 (mode 7)	0~9999	0	-	○	○	○	○	○	○	
14-14	T8 set value 1	0~9999	0	-	○	○	○	○	○	○	
14-15	T8 set value 2 (mode 7)	0~9999	0	-	○	○	○	○	○	○	
14-16	C1 set value	0~65535	0	-	○	○	○	○	○	○	
14-17	C2 set value	0~65535	0	-	○	○	○	○	○	○	
14-18	C3 set value	0~65535	0	-	○	○	○	○	○	○	
14-19	C4 set value	0~65535	0	-	○	○	○	○	○	○	
14-20	C5 set value	0~65535	0	-	○	○	○	○	○	○	
14-21	C6 set value	0~65535	0	-	○	○	○	○	○	○	
14-22	C7 set value	0~65535	0	-	○	○	○	○	○	○	
14-23	C8 set value	0~65535	0	-	○	○	○	○	○	○	
14-24	AS1 set value 1	0~65535	0	-	○	○	○	○	○	○	
14-25	AS1 set value 2	0~65535	0	-	○	○	○	○	○	○	
14-26	AS1 set value 3	0~65535	0	-	○	○	○	○	○	○	
14-27	AS2 set value 1	0~65535	0	-	○	○	○	○	○	○	
14-28	AS2 set value 2	0~65535	0	-	○	○	○	○	○	○	
14-29	AS2 set value 3	0~65535	0	-	○	○	○	○	○	○	
14-30	AS3 set value 1	0~65535	0	-	○	○	○	○	○	○	
14-31	AS3 set value 2	0~65535	0	-	○	○	○	○	○	○	
14-32	AS3 set value 3	0~65535	0	-	○	○	○	○	○	○	
14-33	AS4 set value 1	0~65535	0	-	○	○	○	○	○	○	
14-34	AS4 set value 2	0~65535	0	-	○	○	○	○	○	○	
14-35	AS4 set value 3	0~65535	0	-	○	○	○	○	○	○	
14-36	MD1 set value 1	0~65535	1	-	○	○	○	○	○	○	
14-37	MD1 set value 2	0~65535	1	-	○	○	○	○	○	○	
14-38	MD1 set value 3	0~65535	1	-	○	○	○	○	○	○	
14-39	MD2 set value 1	0~65535	1	-	○	○	○	○	○	○	
14-40	MD2 set value 2	0~65535	1	-	○	○	○	○	○	○	
14-41	MD2 set value 3	0~65535	1	-	○	○	○	○	○	○	
14-42	MD3 set value 1	0~65535	1	-	○	○	○	○	○	○	
14-43	MD3 set value 2	0~65535	1	-	○	○	○	○	○	○	
14-44	MD3 set value 3	0~65535	1	-	○	○	○	○	○	○	
14-45	MD4 set value 1	0~65535	1	-	○	○	○	○	○	○	

Group 14 PLC Setting Group											
Code	Parameter Name	Range	Default	Unit	Control mode						Attribute
					V/F	V/F +PG	SLV	SV	PM SV	PM SLV	
14-46	MD4 set value 2	0~65535	1	-	O	O	O	O	O	O	
14-47	MD4 set value 3	0~65535	1	-	O	O	O	O	O	O	

Group 15 PLC Monitoring Group											
Code	Parameter Name	Range	Default	Unit	Control mode						Attribute
					V/F	V/F +PG	SLV	SV	PM SV	PM SLV	
15-00	T1 current value1	0~9999	0	-	O	O	O	O	O	O	
15-01	T1 current value2 (mode7)	0~9999	0	-	O	O	O	O	O	O	
15-02	T2 current value1	0~9999	0	-	O	O	O	O	O	O	
15-03	T2 current value2 (mode7)	0~9999	0	-	O	O	O	O	O	O	
15-04	T3 current value1	0~9999	0	-	O	O	O	O	O	O	
15-05	T3 current value2 (mode7)	0~9999	0	-	O	O	O	O	O	O	
15-06	T4 current value1	0~9999	0	-	O	O	O	O	O	O	
15-07	T4 current value2 (mode7)	0~9999	0	-	O	O	O	O	O	O	
15-08	T5 current value1	0~9999	0	-	O	O	O	O	O	O	
15-09	T5 current value2 (mode7)	0~9999	0	-	O	O	O	O	O	O	
15-10	T6 current value1	0~9999	0	-	O	O	O	O	O	O	
15-11	T6 current value2 (mode7)	0~9999	0	-	O	O	O	O	O	O	
15-12	T7 current value1	0~9999	0	-	O	O	O	O	O	O	
15-13	T7 current value2 (mode7)	0~9999	0	-	O	O	O	O	O	O	
15-14	T8 current value1	0~9999	0	-	O	O	O	O	O	O	
15-15	T8 current value2 (mode7)	0~9999	0	-	O	O	O	O	O	O	
15-16	C1 current value	0~65535	0	-	O	O	O	O	O	O	
15-17	C2 current value	0~65535	0	-	O	O	O	O	O	O	
15-18	C3 current value	0~65535	0	-	O	O	O	O	O	O	
15-19	C4 current value	0~65535	0	-	O	O	O	O	O	O	
15-20	C5 current value	0~65535	0	-	O	O	O	O	O	O	
15-21	C6 current value	0~65535	0	-	O	O	O	O	O	O	
15-22	C7 current value	0~65535	0	-	O	O	O	O	O	O	
15-23	C8 current value	0~65535	0	-	O	O	O	O	O	O	
15-24	AS1 current value	0~65535	0	-	O	O	O	O	O	O	
15-25	AS2 current value	0~65535	0	-	O	O	O	O	O	O	
15-26	AS3 current value	0~65535	0	-	O	O	O	O	O	O	
15-27	AS4 current value	0~65535	0	-	O	O	O	O	O	O	
15-28	MD1 current value	0~65535	0	-	O	O	O	O	O	O	
15-29	MD2 current value	0~65535	0	-	O	O	O	O	O	O	

Group 15 PLC Monitoring Group											
Code	Parameter Name	Range	Default	Unit	Control mode						Attribute
					V/F	V/F +PG	SLV	SV	PM SV	PM SLV	
15-30	MD3 current value	0~65535	0	-	0	0	0	0	0	0	
15-31	MD4 current value	0~65535	0	-	0	0	0	0	0	0	
15-32	TD current value	0~65535	0	-	0	0	0	0	0	0	

Group 16 LCM Function Group											
Code	Parameter Name	Range	Default	Unit	Control mode						Attribute
					V/F	V/F +PG	SLV	SV	PM SV	PM SLV	
16-00	Main screen monitoring	5~64 when using LCM to operate, the monitored item displays in the first line. (default is frequency command)	16	-	0	0	0	0	0	0	*1
16-01	Sub-screen monitoring 1	5~64 when using LCM to operate, the monitored item displays in the second line. (default is output frequency)	17	-	0	0	0	0	0	0	*1
16-02	Sub-screen monitoring 2	5~64 when using LCM to operate, the monitored item displays in the third line. (default is output current)	18	-	0	0	0	0	0	0	*1
16-03	Display unit	0~39999 determine the display way and unit of frequency command	0	-	0	0	0	0	0	0	
		0: Frequency display unit is 0.01Hz									
		1: Frequency display unit 0.01%									
		2~38: rpm, the set number represents the pole number of motor									
		40~9999: Users specify the format, Inputing 0XXXX represents the display of XXXX at 100%.									
		10001~19999: Users specify the format, Inputing 1XXXX represents the display of XXX.X at 100%.									
20001~29999: Users specify the format, Inputing 1XXXX represents the display of XX.XX at 100%.											
		30001~39999:									

Group 16 LCM Function Group											
Code	Parameter Name	Range	Default	Unit	Control mode						Attribute
					V/F	V/F +PG	SLV	SV	PM SV	PM SLV	
		Users specify the format, Inputting 1XXXX represents the display of X.XXX at 100%.									
16-04	Engineering unit	0: without using engineering unit	0	-	O	O	O	O	O	X	
		1: FPM									
		2: CFM									
		3: PSI									
		4: GPH									
		5: GPM									
		6: IN									
		7: FT									
		8: /s									
		9: /m									
		10: /h									
		11: °F									
		12: inW									
		13: HP									
		14: m/s									
		15: MPM									
		16: CMM									
		17: W									
		18: KW									
		19: m									
		20: °C									
16-05	LCD backlight	0~7	5	-	O	O	O	O	O	O	*1
16-06	Automatic return time	0~120	60	Sec	O	O	O	O	O	O	*1
16-07	Copy function selection	0: Do not copy parameters	0	-	O	O	O	O	O	O	
		1: Read inverter parameters and save to the operator.									
		2: Write the operator parameters to inverter.									
		3: Compare parameters of inverter and operator.									
16-08	Selection of allowing reading	0: Do not allow to read inverter parameters and save to the operator.	0	-	O	O	O	O	O	O	
		1: Allow to read inverter parameters parameters and save to the operator.									
16-09	Selection of operator breaking off (LCD)	0: Display fault when LCD operator is broken off.	0	-	O	O	O	O	O	O	*1
		1: Keep operating when LCD operator is broken off.									

Group 17 Automatic Tuning Function Group

Code	Parameter Name	Range	Default	Unit	Control mode						Attribute
					V/F	V/F +PG	SLV	SV	PM SV	PM SLV	
17-00	Mode selection of automatic tuning	0: rotation autotune	0	-	O	O	O	O	X	X	
		1: static autotune									
		2: stator resistance measurement									
17-01	Motor rated output power	0.00~600.00	-	KW	O	O	O	O	X	X	
17-02	Motor rated current	0.1~999.9	-	A	O	O	O	O	X	X	
17-03	Motor rated voltage	200V: 0.0~255.0	220	V	O	O	O	O	X	X	
		400V:0.0~510.0	440								
17-04	Motor rated frequency	10.0~400.0 10.0~1200.0 (when 00-31 = 1)	60.0	Hz	O	O	O	O	X	X	
17-05	Motor rated speed	0~24000	1750	rpm	O	O	O	O	X	X	
17-06	Pole number of motor	2,4,6,8	4	Pole	O	O	O	O	X	X	
17-07	Number of PG pulse	0~60000	1024	ppr	X	O	X	O	X	X	
17-08	Motor no-load voltage	200V: 50~240	-	V	O	O	O	O	X	X	
		400V:100~480									
17-09	motor excitation current	0.01~600.00	-	A	O	O	O	O	X	X	
17-10	Automatic tuning start	0: invalid	0	-	O	O	O	O	X	X	
		1: valid									
17-11	Error history of automatic tuning	0: No error	0	-	O	O	O	O	X	X	
		1: Motor data error									
		2: stator resistance tuning error									
		3:leakage induction tuning error									
		4: Rotor resistance tuning error									
		5: mutual induction tuning error									
		6: encoder error									
		7: DT Error									
		8: Motor's acceleration error									
		9: Warning									

Group 18 Slip Compensation Group											
Code	Parameter Name	Range	Default	Unit	Control mode						Attribute
					V/F	V/F +PG	SLV	SV	PM SV	PM SLV	
18-00	Slip compensation gain at low speed.	0.00~2.50	-	-	O	X	O	O	X	X	*1
18-01	Slip compensation gain at high speed.	-1.00~1.00	0.0	-	O	X	O	X	X	X	*1
18-02	Slip compensation limit	0~250	200	%	O	X	O	X	X	X	
18-03	Slip compensation filter	0.0~10.0	1.0	Sec	O	X	X	X	X	X	
18-04	Regenerative slip compensation selection	0: invalid	0	-	O	X	X	X	X	X	
		1: valid									
18-05	FOC delay time	1~1000	100	ms	X	X	O	X	X	X	
18-06	FOC gain	0.00~2.00	0.1	-	X	X	O	X	X	X	

Group 19 Wobble Frequency Function Group											
Code	Parameter Name	Range	Default	Unit	Control mode						Attribute
					V/F	V/F +PG	SLV	SV	PM SV	PM SLV	
19-00	Center frequency of wobble frequency	5.00~100.00	20.00	%	O	O	X	X	X	X	*1
19-01	Amplitude of wobble frequency	0.1~20.0	10.0	%	O	O	X	X	X	X	*1
19-02	Jump frequency of wobble frequency	0.0~50.0	0.0	%	O	O	X	X	X	X	*1
19-03	Jump time of wobble frequency	0~50	0	ms	O	O	X	X	X	X	*1
19-04	wobble frequency cycle	0.0~1000.0	10.0	Sec	O	O	X	X	X	X	*1
19-05	wobble frequency ratio	0.1~10.0	1.0		O	O	X	X	X	X	*1
19-06	Upper offset amplitude of wobble frequency	0.0~20.0	0.0	%	O	O	X	X	X	X	*1
19-07	Lower offset amplitude of wobble frequency	0.0~20.0	0.0	%	O	O	X	X	X	X	*1

Group 20 Speed Control Function Group											
Code	Parameter Name	Range	Default	Unit	Control mode						Attribute
					V/F	V/F +PG	SLV	SV	PM SV	PM SLV	
20-00	ASR gain 1	0.00~250.00	-	-	X	O	O	O	O	O	*1
20-01	ASR integral time 1	0.001~10.000	-	Sec	X	O	O	O	O	O	*1
20-02	ASR gain 2	0.00~250.00	-	-	X	O	O	O	O	X	*1
20-03	ASR integral time 2	0.001~10.000	-	Sec	X	O	O	O	O	X	*1
20-04	ASR integral time limit	0~300	200	%	X	X	O	O	O	O	
20-05	ASR positive limit	0.1 ~ 10.0	5.0	%	X	O	X	X	X	X	
20-06	ASR negative limit	0.1 ~ 10.0	1.0	%	X	O	X	X	X	X	
20-07	Selection of acceleration and deceleration of P/PI	0: PI speed control will be valid only in constant speed. For the speed acceleration and deceleration, only use P control.	0	-	X	O	O	O	O	O	
		1: Speed control is valid either in acceleration or deceleration.									
20-08	ASR delay time	0.000~0.500	0.001	Sec	X	X	O	O	O	O	
20-09	Speed Observer Proportional(P) Gain1	0.00~2.55	0.61	-	X	X	O	X	X	O	*1
20-10	Speed Observer Integral(I) Time 1	0.01~10.00	0.05	Sec	X	X	O	X	X	O	*1
20-11	Speed Observer Proportional(P) Gain2	0.00~2.55	0.61	-	X	X	O	X	X	O	*1
20-12	Speed Observer Integral(I) Time 2	0.01~10.00	0.06	Sec	X	X	O	X	X	O	*1
20-13	Low-pass Filter Time constant of speed feedback 1	1~1000	4	ms	X	X	O	X	X	O	
20-14	Low-pass Filter Time constant of speed feedback 2	1~1000	30	ms	X	X	O	X	X	O	
20-15	ASR gain change frequency 1	0.0~400.0	4.0	Hz	X	O	O	X	X	O	
20-16	ASR gain change frequency 2	0.0~400.0	8.0	Hz	X	X	O	X	X	O	
20-17	Torque compensation gain at low speed	0.00~2.50	1.00	-	X	X	O	X	X	O	*1
20-18	Torque compensation gain at high speed	-10~10	0	%	X	X	O	X	X	O	*1
20-19	Over speed (OS) selection	0: Deceleration to stop	1		X	O	X	O	O	X	
		1: Coast to stop									
		2: Continue to operate									
20-20	Over speed (OS) detection level	0~120	115	%	X	O	X	O	O	X	
20-21	Over speed (OS) detection time	0.0~2.0	0.5	Sec	X	O	X	O	O	X	
20-22	Speed deviation (DEV) selection	0: Deceleration to stop	2		X	O	X	O	O	X	
		1: Coast to stop									

Group 20 Speed Control Function Group										
Code	Parameter Name	Range	Default	Unit	Control mode					Attribute
					V/F	V/F +PG	SLV	SV	PM SV	
		2: Continue to operate								
20-23	Speed deviation (DEV) detection level	0~50	10	%	X	O	X	O	O	X
20-24	Speed deviation (DEV) detection time	0.0~10.0	0.5	Sec	X	O	X	O	O	X
20-25	Selection of PG Open	0: Deceleration to stop	1	-	X	O	X	O	O	X
		1: Coast to stop								
		2: Continue to operate								
20-26	Detection time of PG Open	0.0~10.0	2.0	Sec	X	O	X	O	O	X
20-27	PG pulse number	0~60000	1024	ppr	X	O	X	O	O	X
20-28	Selection of PG rotation direction	0: Forward as counter-clockwise rotation	0	-	X	O	X	O	O	X
		1: Forward as clockwise rotation								
20-29	PG pulse dividing ratio	001~132 if parameter is set to XYZ, PG card's dividing ratio will be (X+1)/YZ	1	-	X	O	X	O	O	X
20-30	PG gear ratio 1	1~1000	1	-	X	O	X	X	X	X
20-31	PG gear ratio 2	1~1000	1	-	X	O	X	X	X	X

Group 21 Torque And Position Control Function Group										
Code	Parameter Name	Range	Default	Unit	Control mode					Attribute
					V/F	V/F +PG	SLV	SV	PM SV	
21-00	Torque control selection	0: Speed control	0	-	X	X	X	O	O	X
		1: Torque control								
21-01	Filter time of torque reference	0~1000	0	ms	X	X	X	O	O	X
21-02	Speed limit selection	0: according to AI input	0	-	X	X	X	O	O	X
		1: according to the set value of 21-03								
21-03	Speed limit value	-120~120	0	%	X	X	X	O	O	X
21-04	Bias voltage of speed limit	0~120	0	%	X	X	X	O	O	X
21-05	Positive torque limit	0~300	-	%	X	X	O	O	O	O
21-06	Negative torque limit	0~300	-	%	X	X	O	O	O	O
21-07	Forward regenerative torque limit	0~300	-	%	X	X	O	O	O	O
21-08	Reversal regenerative torque limit	0~300	-	%	X	X	O	O	O	O
21-09	Maximum frequency of position control	0.1~100.0	20.0	Hz	X	X	X	O	O	X
21-10	The command of rotation cycle number	-9999 ~ 9999	0	-	X	X	X	O	O	X

Group 21 Torque And Position Control Function Group

Code	Parameter Name	Range	Default	Unit	Control mode						Attribute
					V/F	V/F +PG	SLV	SV	PM SV	PM SLV	
	of section 0										
21-11	The command of the pulse number of section 0	-9999 ~ 9999	0	-	X	X	X	O	O	X	
21-12	The command of rotation cycle number of section 1	-9999 ~ 9999	0	-	X	X	X	O	O	X	
21-13	The command of the pulse number of section 1	-9999 ~ 9999	0	-	X	X	X	O	O	X	
21-14	The command of rotation cycle number of section 2	-9999 ~ 9999	0	-	X	X	X	O	O	X	
21-15	The command of the pulse number of section 2	-9999 ~ 9999	0	-	X	X	X	O	O	X	
21-16	The command of rotation cycle number of section 3	-9999 ~ 9999	0	-	X	X	X	O	O	X	
21-17	The command of the pulse number of section 3	-9999 ~ 9999	0	-	X	X	X	O	O	X	
21-18	The command of rotation cycle number of section 4	-9999 ~ 9999	0	-	X	X	X	O	O	X	
21-19	The command of the pulse number of section 4	-9999 ~ 9999	0	-	X	X	X	O	O	X	
21-20	The command of rotation cycle number of section 5	-9999 ~ 9999	0	-	X	X	X	O	O	X	
21-21	The command of the pulse number of section 5	-9999 ~ 9999	0	-	X	X	X	O	O	X	
21-22	The command of rotation cycle number of section 6	-9999 ~ 9999	0	-	X	X	X	O	O	X	
21-23	The command of the pulse number of section 6	-9999 ~ 9999	0	-	X	X	X	O	O	X	
21-24	The command of rotation cycle number of section 7	-9999 ~ 9999	0	-	X	X	X	O	O	X	
21-25	The command of the pulse number of section 7	-9999 ~ 9999	0	-	X	X	X	O	O	X	
21-26	The command of rotation cycle number	-9999 ~ 9999	0	-	X	X	X	O	O	X	

Group 21 Torque And Position Control Function Group

Code	Parameter Name	Range	Default	Unit	Control mode						Attribute
					V/F	V/F +PG	SLV	SV	PM SV	PM SLV	
	of section 8										
21-27	The command of the pulse number of section 8	-9999 ~ 9999	0	-	X	X	X	O	O	X	
21-28	The command of rotation cycle number of section 9	-9999 ~ 9999	0	-	X	X	X	O	O	X	
21-29	The command of the pulse number of section 9	-9999 ~ 9999	0	-	X	X	X	O	O	X	
21-30	The command of rotation cycle number of section 10	-9999 ~ 9999	0	-	X	X	X	O	O	X	
21-31	The command of the pulse number of section 10	-9999 ~ 9999	0	-	X	X	X	O	O	X	
21-32	The command of rotation cycle number of section 11	-9999 ~ 9999	0	-	X	X	X	O	O	X	
21-33	The command of the pulse number of section 11	-9999 ~ 9999	0	-	X	X	X	O	O	X	
21-34	The command of rotation cycle number of section 12	-9999 ~ 9999	0	-	X	X	X	O	O	X	
21-35	The command of the pulse number of section 12	-9999 ~ 9999	0	-	X	X	X	O	O	X	
21-36	The command of rotation cycle number of section 13	-9999 ~ 9999	0	-	X	X	X	O	O	X	
21-37	The command of the pulse number of section 13	-9999 ~ 9999	0	-	X	X	X	O	O	X	
21-38	The command of rotation cycle number of section 14	-9999 ~ 9999	0	-	X	X	X	O	O	X	
21-39	The command of the pulse number of section 14	-9999 ~ 9999	0	-	X	X	X	O	O	X	
21-40	The command of rotation cycle number of section 15	-9999 ~ 9999	0	-	X	X	X	O	O	X	
21-41	The command of the pulse number of section 15	-9999 ~ 9999	0	-	X	X	X	O	O	X	

Group 22 IPM Motor Parameter Group											
Code	Parameter Name	Range	Default	Unit	Control mode						Attribute
					V/F	V/F+PG	SLV	SV	PM SV	PM SLV	
22-00	PM motor rated power	0.00~600.00	-	kW	X	X	X	X	O	O	
22-01	PM motor rated voltage	200V: 50~240	220	V	X	X	X	X	O	O	
		400V: 100~480	440								
22-02	PM motor rated current	0.1~999.9	-	A	X	X	X	X	O	O	
22-03	PM motor 's pole number	2~96	6	poles	X	X	X	X	O	O	
22-04	PM motor's rotation speed	0~60000 (22-04, 22-06, only need to set one of them, the program will calculate the other.)	1500	rpm	X	X	X	X	O	O	
22-05	PM motor's maximum rotation speed	0~60000	2000	rpm	X	X	X	X	O	O	
22-06	PM motor frequency	0.0~400.0	75.0	Hz	X	X	X	X	O	O	
22-07	Retain										
22-08	Retain										
22-09	Retain										
22-10	Retain										
22-11	Retain										
22-12	Retain										
22-13	Retain										
22-14	Retain										
22-15	Retain										
22-16	Offset angle of the magnetic pole and PG origin	0~360	0	deg	X	X	X	X	O	X	*4
22-17	PM motor tuning	0: None	0	-	X	X	X	X	O	O	
		1: Magnetic pole alignment and loop adjustment									
		2: Magnetic pole alignment									
22-18	Fault history of PM motor tuning	0. No Error	0	--	X	X	X	X	O	O	*4
		1. static magnetic alignment fault									
		2. without PG option card									
		3. Rotation pole alignment is forced to stop									
		4. Rotation pole alignment is time-out.									
		5. Loop adjustment is time out									
		6. Encoder error									
		7. other errors of motor tuning									
		8. Current abnormality occurs when aligning rotation magnetic pole.									
		9. Current abnormality occurs while loop adjustment.									
10. Restart magnetic pole alignment and loop adjustment											

Chapter 5 Trouble Diagnosis and shooting

5.1 General

Inverter fault detection and early warning / self-diagnosis function. When the inverter detects a fault code displayed on the digital operator, the fault contact output will start acting to cut off the inverter output, so that the motor is coast to stop (The stop way can be selected for some faults). When the inverter detects a warning / self-diagnosis, the digital operator will display a warning / self-diagnostic code, but the fault output of the contact does not act. Once the warning is removed, the system will automatically return to its original state.

5.2 Fault detection function

When the fault occurs, please refer to Table 5.1 for the possible causes and take appropriate measures.

Use one of the following methods to restart:

1. Set one of multi-function digital input terminals (03-00, 03-07) to 17 (Fault reset), so that the fault reset signal is ON.
2. Press the Reset on digital keypad.
3. Cut off the main circuit power and then open it again.

When a fault occurs, the fault message will be stored in the fault information (group 12 parameters).

Table 5.1 Fault information and corrective action

LED display	Description	Possible causes	Corrective action
OC over current	over current : The inverter output current exceeds the OC detection value (about 200% of the rated current)	<ul style="list-style-type: none"> . Acceleration / Deceleration time is too short. . The magnetic switch operation at the inverter output side. . A special motor or applicable capacity is greater than the inverter rated value. . Short circuit or ground fault. 	<ul style="list-style-type: none"> . Prolong acceleration / deceleration time . Check the load wiring . Remove the motor and try to run the inverter
OC			
SC short circuit	short circuit : Inverter output or the load is short circuit	<ul style="list-style-type: none"> . Short circuit or ground fault occurs (08-23 = 1). . The faults such as contact and ground short circuit caused by motor damage, insulation deterioration and wire damage. 	<ul style="list-style-type: none"> . Confirm the load wiring
SC			
GF ground fault	Ground fault: The current of the ground short circuit at output side exceeds 50% of inverter rated output current and 08-23 = 1 (GF function is enabled).	<ul style="list-style-type: none"> . The defects of motor ground fault or DCCT current sensors. . This is equipment protection, not personal protection. 	<ul style="list-style-type: none"> . Check motor wiring and wiring impedance.
GF			
OV over voltage	Over voltage of main circuit: DC voltage exceeds the OV detection value – 410Vdc: 220V class 820Vdc: 440V class (for 440V class, input voltage 01-14 is set to lower than 400V, the OV detection value	<ul style="list-style-type: none"> . Deceleration time is too short, resulting in recovery energy is too high. . The input voltage is too high. . The use of power factor correction capacitor 	<ul style="list-style-type: none"> . Prolong deceleration time . Check the input circuit and reduce the input voltage to comply the specification requirements. . Remove the power factor correction capacitor.
OV			

LED display	Description	Possible causes	Corrective action
	will be decreased to 700Vdc)		
UV under voltage	Under voltage of main circuit: DC bus voltage is lower than the UV detection value or the electromagnetic contactor of DC bus is not used, and at the same time, the inverter is operating. About 190Vdc: 220V class; 380Vdc: 440V class (the detection value can be adjusted by 07-13)	<ul style="list-style-type: none"> . The input voltage is too low. . Phase loss of input power . Acceleration time is too short. . The input Voltage is large fluctuation. . Electromagnetic contactor of DC bus is not used or the feedback signal is not unusual. 	<ul style="list-style-type: none"> . Check the input circuit and the power voltage. . Prolong acceleration time.
UU			
IPL input phase loss	Input phase loss: Phase loss at the input side of the inverter or there is an imbalance great voltage. When 08-09 = 1 (enabed), this fault will be detected.	<ul style="list-style-type: none"> . IPL occurs. . Terminal screws of R/L1, S/L2 or T/L3 are loose or lost. . Instantaneous power loss occurs. . Input voltage fluctuation is too big. 	<ul style="list-style-type: none"> . Check the input voltage. . Fasten terminal screws.
IPL			
OPL output phase loss	Output phase loss: Phase loss at the output side of the inverter. When 08-10=1, this fault detection function is enabled.	<ul style="list-style-type: none"> . The output cable or the internal of motor is damaged. . Terminal screws of R/ L1, S/L2 or T/ L3 are loose or lost. . Motor rated capacity is less than 10% of the inverter rated value. 	<ul style="list-style-type: none"> . Check motor wiring. . Check the motor and the inverter capacity.
OPL			
OH1 Heat sink is overheating	Heat sink is overheating : The temperature of the heat sink is too high. If heat sink overheating fault has occurred with three times in five minutes, it is required to wait 10 minutes before resetting the fault.	<ul style="list-style-type: none"> . Ambient temperature is too high. . The cooling fan has stopped. . Carrier frequency setting is too high. 	<ul style="list-style-type: none"> . Check the ambient temperature of the inverter. . Check the fan or dust and dirt in the heat sink. . Check the carrier frequency setting.
OH1			
OL1 Motor overload	Motor overload: Motor overload protection function is enabled according to the overload protection curve 08-05 = xxx1 of the motor internal (motor overload protection enabling).	<ul style="list-style-type: none"> . Voltage setting of V / F mode is too high, resulting in motor over-excitation. . Motor rated current setting(02-01) is incorrect. . Motor load is too big. 	<ul style="list-style-type: none"> . Check the V / F mode. . Check the motor rated current. . Check the load and the operation cycle time.
OL1			
OL2 Over load of the inverter	over load of the inverter: The overload protection function of the inverter depends on the overload protection curve of inverter internal. When the over load of the inverter is removed, the warning of over load of the inverter will appear. However, if the warning of over load of the inverter has occurred by 4 times in five minutes, it is required to wait 4 minutes to reset the fault.	<ul style="list-style-type: none"> . Voltage setting of V / F mode is too high. . The inverter capacity is too small. . Motor load is too big. 	<ul style="list-style-type: none"> . Check the V / F mode. . Replaced by a higher-capacity inverter . Check the load and the operation cycle time.
OL2			
OT over torque detection	Over torque detection : Inverter output torque is higher than 08-15 (over torque	Mechanical load is too big.	<ul style="list-style-type: none"> . Check the application or operating status . Check whether 08-15 and

LED display	Description	Possible causes	Corrective action
OL	detection level) and exceeds set time of 08-16, then the inverter enables the base block (08-14 = 0).		08-16 are appropriate values
UT under torque detection	Under torque detection: When inverter output torque is lower than 08-19 (under torque detection level) and exceeds set time of 08-20, then the inverter enables the base block (08-18 = 0).	Reduce the mechanical load suddenly. (for example, the belt is broken)	.Check the application or operating status .Check whether 08-19 and 08-20 are appropriate values
UL			
CLB Current Protection Level B	Warning of inverter over current: Inverter current reaches the current protection level B	Inverter current is too big. Motor load is too big.	Check the load and the operation cycle time.
CLB			
OS over speed	Motor over speed : . Motor speed is over than 20-20 (PG Over speed Level) and exceeds set time of 20-21 (PG over speed time). . Subject to 20-19 (= 0 or 1), the inverter will be stopped. . This fault detection is valid only in V / F + PG and SV control mode (00-00 = 1 or 3 or 4). . Motor speed can be monitored by 12-22	. Speed reference is too high. . Excessive occurrence reflects insufficiency in the speed or the degree,	. Check the speed reference gain and the settings of 20-20, 20-21 are appreciate or not. . Adjust the parameters of the set ASR in group 21.
OS			
PGO PG open circuit	PG open circuit detection: .When the inverter is operating, the PG pulse is not detected within the PG open circuit detection time(20-26). .Subject to 20-25(= 0 or 1), the inverter will be stopped. .This fault detection is valid only in V / F + PG and SV control mode (00-00 = 1 or 3 or 4).	. PG connection is incorrect. . PG has no power. . PG wire is broken. . Braking mechanism is enabled.	. Check PG wiring. . Check PG power . Check PG wiring . Check the motor action mechanism
PGO			
DEV speed deviation	speed deviation : .Motor speed deviation is over than the setting of 20-23 (PG speed deviation level) and exceeds 20-24 (PG deviation time). .Subject to 20-22(=0 or 1), the inverter will be stopped. .This fault detection function is valid only in V / F +PG and SV control mode (00-00 = 1 or 3 or 4 .	.The load is too big. .The load has been locked. (for example, the braking mechanism is enabled.). .PG wiring error. .PG the parameter setting (group 20) is incorrect. Acceleration/deceleration time is too short.	.Check mechanical load . .Check the braking mechanism is enabled or not, or reduce the load. .Check PG connection. .Verify the the parameter settings of 20-23 and 20-24 are correct or not. .Prolong acceleration/deceleration time.
DEV			
CE communication error	Modbus communication error : No communication is received in time of 09-06 (communication error detection time) .Subject to 09-07(= 0 to 2), this fault protection is enabled..	.Connection is broken off or the host has stopped communication.	Check all connections and verify all software architecture at the client side.
CE			
FB PID feedback loss	PID feedback loss: In PID feedback loss detection (10-11 = 2, Motor is coast to stop), PID feedback inputs <PID feedback loss detection level (10-12) and the PID	PID feedback sensor can not act properly or it is not install correctly.	.Check PID feedback method setting is correct or not. .Ensure the correct installation and the proper operation of PID feedback signal.
FB			

LED display	Description	Possible causes	Corrective action
	feedback loss detection time is exceeded (10-13).		
STO Safety switch	Safety switch of the inverter	F1 and F2 on the inverter control circuit board are open circuit.	.Check F1 and F2 on the inverter control circuit board are open circuit or not.
StO			
EF1 External fault (S1)	External fault (Terminal S1)		
EF1			
EF2 External fault (S2)	External fault (Terminal S2)		
EF2			
EF3 External fault (S3)	External fault (Terminal S3)		
EF3			
EF4 External fault (S4)	External fault (Terminal S4)	External fault input is received by multifunction digital input terminals. Subject to 03-00 to 03-07(= 25), Inverter external fault selection 08-24= 0 or 1, Significant fault.	. Check the faults of external causes. . Reset the external fault of multi function digital input.
EF4			
EF5 External fault (S5)	External fault (Terminal S5)		
EF5			
EF6 External fault (S6)	External fault (Terminal S6)		
EF6			
EF7 External fault (S7)	External fault (Terminal S7)		
EF7			
EF8 External fault (S8)	External fault (Terminal S8)		
EF8			
CF07 Motor control fault	Motor control fault	In SLV mode, running fault.	. Perform rotational auto-tuning . If rotational auto-tuning can't be performed, please perform the static auto-tuning, or increase the set value of 01-08.
CF07			
FU fuse open	DC fuse : open circuit DC fuse (Models 230V 50HP or above, 460V 75HP or above) open circuit .	.The power transistor is damaged due to the short circuit at the inverter output side. .Check there are short circuit or not between the terminal ⊖ and U/T1, V/T2, W/T3.	.Check there is short circuit or not between the motor and the wire or the insulation is damaged. . Repair / replace the inverter.
Fu			

5.3 Warning / self-diagnosis detection function







When the inverter detects a warning, the digital operator will display the warning code (flash), and the fault output contact will not act. Once the warning is removed, the system will automatically restore the original state.







When the inverter detects a self-diagnosis function (for example, there is an invalid setting or two parameters are contradictive), the digital operator will display the self-diagnosis code, and the fault output contact will not act. Before the parameter has been correctly set, the inverter can not execute the operation command.







When a warning or a self-diagnostic error occurs, refer to Table 5.2 to confirm and correct the error.







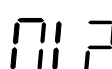

When the RESET key is pressed at this time, the warning message (flash) disappears. If the warning or self-diagnostic error still exists, the warnings will be displayed again in 5 seconds.







Table 5.2 warning / self-diagnosis and corrective actions







LED display	Description	Possible causes	Corrective action
OV (flash) over voltage	Voltage of main circuit: The DC bus voltage exceeds the OV detection level, and the inverter has stopped. 410Vdc: 230 V class 820Vdc: 460 V class	The input power voltage is too high.	Check the input power voltage
			
UV (flash) under voltage	Voltage of main circuit: The DC bus voltage is lower the UV detection level, and the inverter has stopped. 190Vdc: 230V class 380Vdc: 460V class (07-13 can set the detection level)	. The input power voltage is too low. . Momentary power loss occurs.	. Check the input power voltage. .Check the input circuit. .Check the main circuit MC.
			
OH2 (flash) Inverter over heating warning	Inverter over heating warning: Use multi function digital input terminals to input the inverter over heating warning. (03-00 ~03-07=31)	Multi function digital input terminal receives the occurrence signal of external over heating warning.	Check the external condition
			
OT (flash) over torque detection	over torque detection : The inverter output current is higher than 08-15 (OT detection level) and exceeds set time of 08-16. Subject to 08-14=1, the inverter continues operation.	Mechanical load is too big.	.Check the application or the machine's operation status. .Check the set values of 08-15 and 08-16.
			
UT (flash) under torque detection	Under torque detection : The inverter output current is lower than 08-19 (under torque detection level) and exceeds set time of 08-20. Subject to 08-18=1, the inverter continues operation.	Mechanical load is removed momentarily. (for example, the belt is broken off)	.Check the application or the machine's operation status. .Check the settings of 08-19 and 08-20.
			
bb1 (flash) External block	External block (Terminal S1)	External block input is received by multifunction digital input terminals.	.Remove the causes of external block.
			

LED display	Description	Possible causes	Corrective action
bb2 (flash) External block	External block (Terminal S2)		
			
bb3 (flash) External block	External block (Terminal S3)		
			
bb4 (flash) External block	External block (Terminal S4)		
			
bb5 (flash) External block	External block (Terminal S5)		
			
bb6 (flash) External block	External block (Terminal S6)		
			
bb7 (flash) External block	External block (Terminal S7)		
			
bb8 (flash) External block	External block (Terminal S8)		
			

LED display	Description	Possible causes	Corrective action
OS (flash) Motor over speed	Motor over speed : . Motor speed deviation is higher than 20-20 (PG over speed level) and exceeds set time of 20-21 (PG over speed time). . This fault is valid only in V / F +PG and SV control mode (00-00 = 1 or 3 or 4) .	.Speed reference is too high. .Speed response overshoot or deficient response occurs.	.Check the speed reference gain and check 20-20, 20-21 settings. .Adjust ASR setting (group 20 parameter).
			
PGO (flash) PG open circuit	PG open circuit detection: .When the inverter is operating, PG pulse is not detected within the PG open circuit time (20-26). .Subject to 20-25(= 0 or 1), the inverter will be stopped. . This fault is valid only in V / F +PG and SV control mode (00-00 = 1 or 3 or 4) .	.PG wiring error . .PG power is removed. .PG is broken off. .Braking mechanism is enabled.	.Check the PG wiring. .Check the PG input power.
			
DEV (flash) speed deviation	Motor speed deviation: .Motor speed deviation is higher than 20-23 (PG speed deviation level) and exceeds set time of 20-24 (PG deviation time). .Subject to 20-22(=0 or 1), the inverter will be stopped. . This fault detection function is valid only in V / F +PG and SV control mode (00-00 = 1 or 3 or 4) .	. The load is too big. . The load has been locked. (For example, the braking mechanism is enabled.) . PG wiring error. . PG the parameter setting (group 20) is incorrect. . Acceleration/deceleration time is too short.	. Check mechanical load. . Check the braking mechanism is enabled or not, or reduce the load. . Check PG connection. . Verify the the parameter settings of 20-23 , 20-24 and 20-28 are correct or not. . Prolong acceleration/deceleration time.
			
OL1 Motor over load	Motor over load: Motor over load protection function is enabled according to the over load curve of motor internal 08-05 =xxx1(Motor over protection is enabled.).	.The voltage setting of V/F mode is too high, resulting in motor over excitation. . Motor rated current setting (02-01) is incorrect. . Motor load is too big.	.Check V/F mode . .Check Motor rated current . .Check the load and operation cycle. .Check V/Fmode .
			
OL2 over load of the inverter	over load of the inverter: Over load fault of the inverter has occurred , but time is less than 4 minutes (if time is over 4 minutes, this warning will be cleared automatically.)	. The voltage setting of V/F mode is too high, and the inverter capacity is too small. .Motor load is too big.	. Replaced by higher capacity inverter .Check the load and the operation cycle
			
CE (flash) communicatio n error	Modbus communication error : .when 09-07= 3, no communication data is received over 2 seconds.	. Connection is broken off. . The host has stopped the data transmission.	Check all connections and verify all software architecture at the client side.
			
CLA over current protection level A	Warning of inverter over current: Inverter current reaches current protection level A	Inverter current is too big. .Motor load is too big.	Check the load and operation cycle.
			

LED display	Description	Possible causes	Corrective action	
CLB over current protection level B 	Warning of inverter over current: inverter current reaches current protection level B	Inverter current is too big. .Motor load is too big.	Check the load and operation cycle.	
ADL current feedback protection level 	Warning of inverter over current: inverter current reaches current feedback protection level	Inverter current is too big. .Motor load is too big.	Check the load and operation cycle.	
EF1 (flash) External fault (S1) 	External fault (Terminal S1)	.External fault input is received by multifunction digital input terminals. .Subject to 08-24=2, the inverter continues operation.	.Remove external fault causes. .Reset the external fault of multifunction digital input	
EF2 (flash) External fault (S2) 				External fault (Terminal S2)
EF3 (flash) External fault (S3) 				External fault (Terminal S3)
EF4 (flash) External fault (S4) 				External fault (Terminal S4)
EF5 (flash) External fault (S5) 				External fault (Terminal S5)
EF6 (flash) External fault (S6) 				External fault (Terminal S6)
EF7 (flash) External fault (S7) 				External fault (Terminal S7)

LED display	Description	Possible causes	Corrective action
EF8 (flash) External fault (S8)	External fault (Terminal S8)		
			
EF9 (flash) error of forward/reve rsal rotation	.Forward and reversal rotation command (2 –wire type operation) are input at the same time within 0.5 second or above. .Subject to 07-09 to set the motor stop method. . After the fault is removed, the inverter returns normal status.	Forward and reversal rotation command are input at the same time. (refer to 2–wire type operation)	Check external procedure logic
			
SE01 Rang setting error	The parameter setting exceeds the range: When the parameter setting exceeds the allowed range.	.The parameter setting exceeds the allowed range . In some situation, the parameter setting will be based on the other parameter setting(for example 02-00>02-01, 02-20>02-21 or 00-12>00-13 and so on).	Check the parameter setting.
			
SE02 Digital input terminal error	Errors of multifunction digital input terminal	Errors of multifunction digital input terminals (03-00 to 03-07), as described in the following: ①UP/DOWN commands are not set at the same time(they must be used together). ② UP/DOWN commands (08 and 09) and ACC/DEC commands (11) are set at the same time. ③ Speed search 1 (19, maximum frequency) and Speed search 2 (34, from the set frequency) are set at the same time.	Check the parameter setting
			
SE03 V/f curve error	V/f curve setting error:	V/F curve setting is not based on the following architecture: ① 01-02 > 01-12 >01-06 > (Fmax) (Fbase) (Fmid1) 01-08; (Fmin) ②01-16 > 01-24 > 01-20 > 01-22; (Fmax(2)) (Fbase(2)) (Fmid(1)) (Fmin(2))	Confirm V/F parameter setting.
			
SE05 PID selection error	PID selection error:	10-00 and 10-01are all set to 1(AI1) or 2 (AI2) at the same time.	Check the set values of paramters10-00, 10-01
			

LED display	Description	Possible causes	Corrective action
HPErr Model selection error 	Inverter capacity setting error: Inverter capacity setting 13-00 does not match the rated voltage.	The inverter capacity setting (13-00) does not match the voltage class of the hardware.	Check the inverter capacity setting (13-00) matches the voltage class of the hardware or not.
SE07 PG card error 	Inverter PG card setting error	This inverter PG card has not been installed.	Check the inverter PG device. Check the control mode
SE08 PM Motor mode error 	A510 inverter of this horse power does not support the PM Motor mode	Inverter does not support PM Motor mode	Check the control mode
SE09 PI setting error 	Inverter PI setting error	Inverter PI option (03-30) selection conflicts with PID source (10-00 and 10-01).	Check inverter PI option (03-30) selection and PID source (10-00 and 10-01)
FB (flash) PID feedback breaking 	PID feedback breaking: PID feedback breaking detection is enabled (when 10-11=1), keep on operation, and PID feedback inputs the PID feedback breaking detection time (10-13)of PID feedback breaking level.	PID feedback signal (such as the transformer) does not act or is incorrectly installed.	.Check the set PID feedback method is correct or not. .Ensure correct installation and the proper operation of PID feedback signals.
USP (flash) Unattended Start Protection 	Unattended Start Protection (USP) is enabled (enabled in booting)	. USP in booting (set by multi-function digital input) is enabled, the inverter will not accept any operation command. . Before the warning information is removed, the inverter can't enter the operating mode. (Please refer to related instructions in the full manual 03-00 - 03-08 = 50)..	.Operation command is turned off, or terminal reset operation is performed (03-00 to 03-07 are 3), or use the RESET key on the digital operator to reset.. .Close the USP signal and restart the power.

5.4 Auto-tuning error

When the auto-tuning fault occurs, the fault of "AtErr" will be displayed on the digital operator and the motor stops. The fault information is displayed on the 17-11. The fault digital output contact does not act. Refer to Table 5.3, to identify and correct the faults.

Table 5.3 Auto-tuning fault and corrective actions

Error	Description	Cause	Corrective action
01	Motor data input error	<ul style="list-style-type: none"> · Input data error of auto-tuning · Error relationship between the motor output current and motor rated current 	<ul style="list-style-type: none"> · Check the input data for auto-tuning (17-00 to 17-09). · Check the inverter capacity
02	Tuning error of the resistor R1 of motor wire to wire.	<ul style="list-style-type: none"> · Auto-tuning is not completed within a certain time · Auto-tuning result is beyond the parameter setting. · Exceed the motor rated current. · Three phase output of the inverter is broken off. 	<ul style="list-style-type: none"> · Check the input data of auto-tuning (17-00 to 17-09) · Check motor connection. · Disconnect all loads connected to the motor. · Check the inverter current detection circuit, including the current sensor. · Check motor connection. · Check motor installation.
03	Tuning error of motor leakage inductance		
04	Tuning error of motor rotor resistance R2.		
05	Tuning error of motor mutual inductance Lm		
07	Deadtime compensation detection error		
06	Motor encoder error	Motor encoder noise is too large	Confirm the motor rated current (02-01, 02-21).
08	Motor acceleration error (only suitable for the rotary type auto-tuning).	Motor fails to accelerate in specified time (00-14=20sec).	<ul style="list-style-type: none"> · Increase the acceleration time (00-14) . · Disconnect all loads connected to the motor.
09	Other errors of auto-tuning	Other errors of auto-tuning (except the ATE-01~ATE-08 error, such as the no load current is higher than 70%, rated current or torque exceeds 100 % of the reference).	<ul style="list-style-type: none"> · Check motor connection. · Check the input data of auto-tuning

5.5 PM motor auto-tuning error

When the PM motor auto-tuning fault occurs, the fault information of “IPErr” (PM motor tuning failure) will be displayed on the digital operator and the motor stops. The fault information is displayed on 22-18. The fault digital output contact does not act. Refer to Table 5.4, to identify and correct the faults.

Table 5.4 Auto-tuning fault and corrective actions for PM motor

Error	Description	Cause	Corrective action
01	Static magnetic pole alignment failure	·Error relationship between motor output current and motor rated current.	·Check input data of auto-tuning (22-02). ·Check the inverter capacity ·Check Motor connection
02	Without PG option card	·magnetic pole can not be aligned without PG option card	·Check PM's PG card has been installed properly or not.
03	Rotary magnetic pole alignment is forced to stop.	·system abnormality	·Check it enters other protection programs or not.
04	Rotary magnetic pole alignment is time out	·Motor can not operate properly.	·Check Motor connection
05	Circuit tuning is time out	·System abnormality occurs in circuit tuning process.	· Check it enters other protection programs or not.
06	Encoder error	·Motor encoder noise is too large.	·Check PG card has been grounded or not.
07	Other motor tuning error	·Other errors of auto-tuning	·Check motor connection. ·Check input data of auto-tuning
08	Current abnormality occurs in rotary magnetic pole alignment.	·Motor can not operate at low speed.	·it is possible that the connections of PG card A, B are reversal. It can be redone. The system will automatically adjust the wiring definition. ·Check motor connection
09	Current abnormality in circuit tuning.	·Error relationship between motor output current and motor rated current.	·Check input data of auto-tuning (22-02). ·Check the inverter capacity
10	Retry magnetic pole alignment and circuit tuning.	Auto-tuning is not completion.	Retry magnetic pole alignment and circuit tuning.



TECO Electric & Machinery Co., Ltd.

10F., No.3-1, Yuancyu St., Nangang District,

Taipei City 115, Taiwan

Tel : +886-2-6615-9111

Fax : +886-2-6615-0933

<http://www.teco.com.tw>

Distributor

Ver:01 2012.01

This manual may be modified when necessary because of improvement of the product, modification, or changes in specifications, This manual is subject to change without notice.